



# Journal of the CALIFORNIA HISTORICAL RADIO SOCIETY



Master of Ceremonies  
Stan Bungler

Auctioneer  
Dan Ashley



Don Neely's Royal Society Quintet

## Radio Day By The Bay 2018



Pat Novak For Hire - Radio Play





FROM THE BIRTHPLACE OF BROADCASTING  
**CALIFORNIA HISTORICAL RADIO SOCIETY**  
 HOME OF THE BAY AREA RADIO MUSEUM & HALL OF FAME

The California Historical Radio Society (CHRS), is a non-profit educational corporation chartered in the State of California. Formed in 1974, CHRS promotes the restoration and preservation of early radio and broadcasting. Our goal is to enable the exchange of information on the history of radio, particularly in the West, with emphasis on collecting, preserving, and displaying early equipment, literature, and programs. Yearly membership is \$30 (\$40 non-USA).

### CHRS Museum in Alameda

CHRS has been fortunate to through the generosity of its donors to purchase a home for the CHRS museum and education center. It is located at 2152 Central Avenue. The building was built in 1900 as a telephone exchange.

CHRS volunteers are actively restoring the building to make it optimal for use. Our goal is to create an environment to share our knowledge and love of radio and enable us to create an appreciation and understanding for a new generation of antique radio collectors and historians.

Please come visit us any Saturday 9am to 3pm. Visitors and groups welcome at other times by appointment; Contact Steve Kushman.



#### Contact us:

CHRS, PO Box 31659, San Francisco, CA 94131  
 or [info@californiahistoricalradio.com](mailto:info@californiahistoricalradio.com)

Visit us at: [www.CaliforniaHistoricalRadio.com](http://www.CaliforniaHistoricalRadio.com)

#### Officers & Directors

- Mike Adams - Chairman, Webmaster
  - Steve Kushman - President, Radio Central Project Manager
  - Scott Robinson - Vice President, Technical Ops.
  - Jaime Arbona - Secretary, Mailing
  - Richard Watts - Treasurer, Membership, Publications, Collections
  - Philip Monego - Director at Large
  - Dennis Monticelli - Education
- W6CF Trustee, John Staples, W6BM

#### CHRS Central Valley Chapter (CVC)

Richard Lane - Chairman

#### Staff

- Bart Lee - Counsel Emeritus, Hist., Archivist
  - Len Shapiro - BARM Executive Director
  - Walt Hayden - Radio Central Planning Consultant
  - John Stuart - Resident Engineer, Networks
  - Keith Scott - Manager, Landscaping Ops.
  - Tom Bonomo - Investments, Name Badges
  - Dave Billeci - Video Production
  - Paul Shinn - Amateur Radio Operations
  - David Vasquez - Electrical Transcription Project
  - Larry Clark - Technical Advisor & Librarian
- Lunch crew: Cynthia Edwards, Keith Scott, Judy Mears, Betty Cosmos

© California Historical Radio Society, 2018.

All rights reserved. No part of this publication may be reproduced in any form, or by any means, without prior written permission from CHRS, except that you may make "fair use" of quotations of text fully attributed by you to the source (this Journal) and the author.

## Contents of the Journal

### COLUMNS

- 4 **From The President**  
Steve Kushman
- 5 **From the Chairman**  
Mike Adams
- 6 **Volunteer of the Year**
- 7 **CHRS Central Valley Chapter News**  
Richard Lane
- 8 **Radio Central Update**

### FEATURE ARTICLES

- 9 **A Custom Precision Tube Tester**  
John Staples
- 17 **KDIA: Power to the People**  
David Jackson
- 23 **A Radio Odyssey (Part 3) — The Science Museum in London, U.K.**  
Bart Lee
- 28 **Internet Radio Project**  
Brett van Zuiden
- 33 **Bay Area Radio Hall of Fame 2018 Inductees**  
David Jackson

**Front & Rear Covers:** Images from Radio Day 2018.

### From the Editor

In this journal, John Staples offers a straight forward design for a tube tester capable of precise measurement. David Jackson provides history of KDIA, the Bay Area Radio Hall of Fame station of the year. Bart Lee presents his third visit to a European radio museum. Brett van Zuiden offers a method for retrofitting a vintage radio for the internet. David Jackson summarizes the induction of the new 2018 members to the Bay Area Hall of Fame. The covers offer a glimpse of the 2018 Radio Day festivities. I wish to thank all the authors for their articles, support, and scholarly contributions.

I am always in need of quality content related to broadcast radio, ham radio, and television. If you have something to contribute, I urge you to let me know. I am especially interested in technical content. It can be of two types, a narrow topic in depth or a more broad topic with less depth. Enjoy . . .

Richard Watts, jrchrs@comcast.net



## From The President

by Steve Kushman

The State of our Society...

At this writing, CHRS is doing pretty well. Our favorite historical radio society is thriving. Are other vintage radio groups thriving? Well maybe not so much. CHRS is very fortunate to have many good things going for us. We aim towards the future when this group of white haired and balding people are gone. How do we plan to do this? Here are some of the ways. We raised the money to purchase our own historic building. We are one of the only vintage radio groups in the Country that owns its own facility.

We currently have 400 members and many non-member supporters. But these people are not any old members and supporters... Our members and supporters are special. Why? Because they are passionate about radios and broadcasting history. And they know that CHRS is on a great mission of historic preservation and presentation. We have proved that by our 10 year tenure at KRE and our four years at Radio Central where we have learned so much. People love to volunteer at Radio Central because there is nothing like it in this part of the Country.

We have reached out to the broadcasting community as another way of insuring our future. We encourage other radio collecting groups to do the same. It's a way to revitalize stagnant simple collecting groups. By broadening our focus to include the medium that emanates from the radios we have been collecting for years, we open many new doors into resources that we can use to preserve and present radios and radio history. So our acquisition of the Bay Area Radio Museum, on-line, and its Bay Area Radio Hall Of Fame plus the acquisition of the Society Of Wireless Pioneers has helped turn CHRS from a radio collecting group into a true 'Historical Radio Society'.

By showcasing what we as an organization have accomplished, it encourages support to flow in. Support comes in the form of extremely hard working volunteers, many donations of vintage gear, (some destined for our Museum), and the most important expression of support in the form of monetary gifts.

One recent gift from a former broadcaster's family is noteworthy. Dr. Beverly Potter has donated \$100,000 to support CHRS. The gift was presented in the memory of Dr. Potter's mother, Alice, who died recently at age 90. Alice Potter was one of the people who left a lasting impact on Bay Area radio. In the early 1970's Alice, who started as a copy girl at Berkeley's KPAT/KRE some years earlier, was asked to sell radio time. In the man's world of radio ad sales during that time, Alice became a star and was promoted to Sales Manager. In 1974 she was promoted to KRE's General Manager. Both positions were traditionally men's jobs. But Alice flourished and broke the 'glass ceiling' over 40 years ago. So, CHRS is proud to have Alice in the Bay Area Radio Hall Of Fame, Class of 2012 and honored to have this generous donation in her name. Thank you Dr. Potter.

As we approach the end of 2018 it's time to think about your year end donations to CHRS... Especially to our construction fund. Our downstairs waterproofing project is wrapping up and has given us space for a console display and conference area, a television display, a new W6CF ham shack and the Hall of Communications. And we now have two new stairways and an approved ADA handicapped wheel chair lift. Next we intend to complete the physical Radio Hall Of Fame and vintage radio control room. Stand by for details and in the meantime, please send back your renewals with your generous tax deductible donations.

I always end up saying here how honored I am to be part of this wonderful organization. Well, nothing has changed. It has only gotten better as we grow and continue to be blessed with such a terrific group of volunteers. I am proud to be one of you. And I appreciate everyone's good thoughts about my wife, Janice.

I'm always available for comments, complaints or suggestions. Don't hesitate to contact me if you have something to say about CHRS... good or bad. Your comments are welcomed.

Best Regards, *Steve*  
(415) 203-2747  
Steve@chrsradio.com

◇

## From The Chairman

by Mike Adams

We have created a radio museum. It seems like only yesterday that we were housed in the quirky but too small KRE. After ten years in Berkeley we were shown the door, but good fortune brought us to Alameda and the opportunity to purchase the historic telephone exchange on Central Ave. We thank our generous CHRS members for their financial support. But we had a lot of work to do for our facility to be suitable. Then the unseasonably heavy rains saturated the ground and showed us the degraded condition of our 118 year old floor; it leaked like a sieve and we became a temporary Noah's Ark. Consoles and table radios were marched two by two into storage to gather dust while we reimaged, repaired and rebuilt. And while the rain may have slowed us down it did not dampen our resolve. Leadership to realize all of what we have achieved so far has been provided by the indefatigable Steve Kushman. (applause)

Let's talk about our future. Now that we have finished the repairs to our lower floor, your Board of Directors must now plan the completion of the transition from a hobby club to a radio museum. To that end, we are exploring big questions about what our future at Radio Central should be, the nature of our visitor's experience, and for whom it should be designed. We are just beginning to plan exhibits that tell stories while highlighting important pieces from our extensive collection. Exhibits take careful planning and will be realized through the ideas and energy of our members. Our first exhibit is television, now being created by John Staples. This will be followed by the ham shack and W6CF, led by Denny Montecelli, and the Hall of Communication under the direction of Bart Lee. Then we go upstairs and build the main gallery in our 118 year old building.

Stepping back, I am reminded of a larger picture. CHRS is a California non-profit 501(c) (3) corporation created in 1974 to promote the research, preservation, publication, education, and presentation of early radio and broadcasting. To realize this, the Society has selectively amassed collections of the histories of Bay Area radio stations and it's personalities, plus thousands of radios and other communications devices of the 20th century — from wireless to radio to television, from crystal to vacuum tube to transistor, from headphones to loudspeakers. For radio scholars we have a complete communications library containing the histories of radio technology and programming as it was created for amateur and citizen audiences.

In addition to actual devices in our collection, we have merged into our mission the history, media, and archives of sister organizations. The first of these is the Bay Area Radio Museum, a revered and popular on-line presence that provides access to the history and sounds of Bay Area radio. Next, the Broadcasting Hall of Fame, a salute to the legendary radio personalities, stations and programming in the form of air checks, photos and stories. There will soon to be a space in the museum dedicated to recognizing exceptional contributions to Bay Area radio. We have archives of The Society of Wireless Pioneers and volunteer Bob Rydzewski is working hard to put these on-line. We hold the FCC-licensed amateur station W6CF, the station operated by the late James Maxwell. In our fully functioning shop, members repair radios for auction and display, and it is in this space that we teach classes in radio repair. When we are fully built we will have a complete radio museum featuring artifacts from early wireless to the present day, all told as stories and much of it interactive. We will have a small theatre for live presentations and a broadcast control room and studio as it was in the early years. OK, we have lots of equipment. But what is our purpose, our reason to exist?

Some of us may remember that CHRS began over four decades ago as a radio collecting hobby club. But now with the responsibility of museum ownership, we must broaden our audience. Our original membership is mostly over age 65 who are primarily composed of collectors. Yet CHRS will need to expand its appeal to create the same appreciation for radio as those who remember it well. We seek to attract high school to college to those of millennial age and beyond. As a university professor I would ask students in my communications history class this question: How many of you have radios? Several decades ago all would raise their hands in the affirmative. Now when I ask the question only 1 or 2 in a class of 100 admit to owning a radio. This is my cue to ask about their car radio, and to start a discussion about defining radio. I'll admit I listen to Bay Area radio on a smart phone app and I am a long-time subscriber to SiriusXM. It's all radio. How can our museum reach those who have never owned, never tuned a radio?

How can we educate and excite these new audiences about the cultural as well as the technical importance of radio? How do we communicate the meaning of radio to a very diverse Bay Area population? How can we remain viable long after our older hobbyist base ages out? How can we explain in a compelling way how wireless 100 years ago relates to the wireless device currently in the hand of every man, woman and child? Even more important, how can we serve the Bay Area broadcast community, those professionals who were the announcers, engineers and managers of the formative years of radio? We have their transmitters, control boards and microphones. We want those broadcasters and their listening audiences as museum patrons.

These are our challenges. Your California Historical Radio Society remains committed to providing a forum for exchanging ideas, publishing stories and displaying the artifacts of the history of radio and broadcasting. But we must make our knowledge and our artifacts relevant to the new audiences we seek to serve. We are asking big questions: How do we attract to our museum the broadcasters that we honor? How do we attract other organizations to use the museum as a meeting place as the Bay Area Society of Broadcast Engineers does? What do we do to attract them? How do we reach those of millennial age? How do we move from a static radio hardware museum to one that speaks to the cultural importance of communications technology and programming? How do we continue to fund it, and how do we insure our viability in the future? To meet our challenges, we, the Board, ask for your help, your skills, your commitment, and your experience to realize something truly special. ◇

---

## John Stuart—Volunteer of the Year

by Steve Kushman

In a unanimous vote by the Board of Directors our 'Resident Engineer' John Stuart has been recognized for his efforts and participation in our building systems and his involvement in our construction projects. Over the years, John has been instrumental to the success of many CHRS initiatives both at KRE and currently at Radio Central. He has spent countless hours designing, doing architectural research, drawing, and revising our plans for permitting and construction projects. Projects have included planning and drawings for all room, seismic, and structural renovations, property site planning, building power distribution design, front Facade design, the ADA lift, the new concrete floor, and sump system. Also, John installed, configured, and maintains the telephone, internet, and WiFi services at RC. Even though he works mostly behind the scenes, his contributions are very apparent and the quality of his results are impressive. He is greatly appreciated for his work, contributions and support for the success of CHRS and Radio Central. Thank you John! ◇



## CHRS Holiday Social

*Saturday December 15th - 11am*

### Guest speakers:

**Steve Hyman** - Grandson of Benjamin Abrams,  
1922 owner of Emerson Radio & Phonograph

**Bob Rydzewski** - SOWP Archivist

*And Pot Luck Lunch!*



# CHRS Central Valley Chapter News

by Richard Lane

19<sup>th</sup> Annual CVC Swap Meet: On October 6<sup>th</sup>, the Central Valley Chapter hosted their 19<sup>th</sup> annual swap meet at the Stanislaus County Fairgrounds. Sixteen sellers were on hand to sell radios and other vintage equipment, some hailing from as far away as Fresno and Redding. The range of radios were from the restoration project to a fully restored Scott chrome chassis receiver. Also, at the CVC information booth area was 40 items from a CVC member estate, many which were sold; the 50/50 raffle and \$1 radio raffle was very active. Breakfast burritos, coffee, juice and donuts were on hand for those working up an appetite buying and selling radios. In all, the meet was very well attended and seller items were of high quality.

In other news there will be a Spring auction of the Greg Greenwood estate featuring many vintage ham and military items of all types. This sale will take place in the Spring and is to be announced. Anyone wishing to be notified of the auction contact Rich Lane at [radiodoc56@msn.com](mailto:radiodoc56@msn.com) or visit the CVC website at [cvantiqueradio.com](http://cvantiqueradio.com) for announcements.

The CVC is currently working to better formalize Chapter recognition by the CHRS Executive Board. Representatives of the CVC will meet at the CHRS Board meeting on October 27.

Membership meetings are held on the 3rd Saturday every month in the CVC clubhouse at the corner of Bradbury and Commons just Southwest of Turlock. Start time is 1:30 PM in Winter and 10:30AM during the Summer, consult the website exact times.

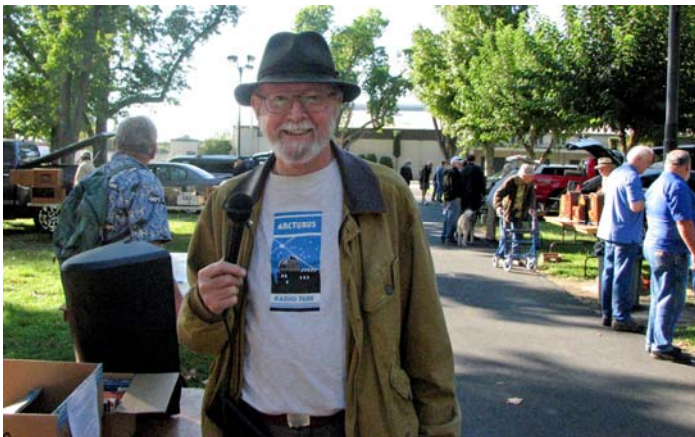

# Radio Central Update

## RENOVATION

**Downstairs Gallery:** Construction is nearly complete in the downstairs gallery and W6CF ham shack. Walls were sheet rocked, flooring installed, electrical and lighting installed. and the ADA lift was installed. Remaining is just to complete trim work and configure the gallery for exhibits. The W6CF ham shack can now be configured and made operational.

**Roof Repair:** A roofing contractor made essential repairs to the roof to provide many more years of services. Platforms were added to accommodate radio antenna mounts.

**Upstairs Galleries:** Planning has been done to determine the optimal configuration of the Main Gallery, the Hall of Fame Gallery, the Control Room display, and the Audio Transfer function. Agreement has been reached and detailed plans are being developed to complete this final phase of interior renovation.

**Facade Restoration:** It is the goal to restore the front of the building as it was when originally built in 1900. The photo above shows that facade. During recent construction projects, portions of the original facade can now be seen. It appears that much of the original facade is intact although its condition is still unknown. A separate renovation project is soon to begin. Accomplishing this will require financial and volunteer support. We will also seek support from the community as Alameda takes pride in the heritage of its buildings. It is our goal that CHRS Radio Central be a place of pride in the community and an interesting venue for events.



Original circa 1900 exterior front elevation of 2152 Central Ave.

## ACTIVITIES

The Board has been investigating various operational approaches for education centers and museums. The Board continues to consult with peer museum organizations in the Bay Area, and with non-profit management consultants with museum focus.



Congratulations to Christopher for passing the Amateur Radio General Exam.

Exhibit committees are being formed to design specific displays. For example, John Staples is leading a committee to design a television display, Mike Adams is leading the design of the Hall of Fame gallery, and Denny Monticelli is the lead for configuring W6CF and making it operational.

CHRS has continued to have a presence at Bay Area antique fairs and other events to promote vintage radio. To educate and expand the public's interest in radio and CHRS, a selection of radios is available to the public for a donation.

Radio restoration continues in the shop.



Drugstore tube tester restored by Hil Hampton .



# A Custom Precision Tube Tester

By John Staples, W6BM

A simple but precise tube tester is presented.

Good tube testers have become expensive. The software-driven units are even more expensive, and some rely on obsolete computer operating systems or have limited number of pre-defined tube types.

Other well-regarded testers do not allow all parameters to be varied: in particular, the AC grid stimulus signal provided to the tube for a transconductance test may operate the tube outside its linear region, giving an incorrect value. This is particularly true for low-power voltage amplifier tubes, such as 12AX7s, which operate at a low bias setting where the tester applies an AC test voltage that is a sizable fraction of the bias voltage.

A simple tester has been designed and operated, and tested against other laboratory-grade testers such as the author's AN/USM-31, the military version of the Weston 686, an industry standard, which applies a grid stimulus signal as large as 1 volt RMS for low-transconductance tubes.

The goals of the design are:

- Simple to construct and operate
- Calibration depends on the simple measurement of only two items: a resistor and a transformer
- All parameters variable and measurable
- Can use an oscilloscope to view actual output waveform
- Protection of the output monitor from internal transients
- Insure stability during measurement (no parasitics or oscillations)
- Versatile filament/heater configurations
- A simple gas check
- Use a test signal frequency other than line-frequency related

The ideal configuration of a transconductance tester for a 5-element tube (pentode) is shown here:

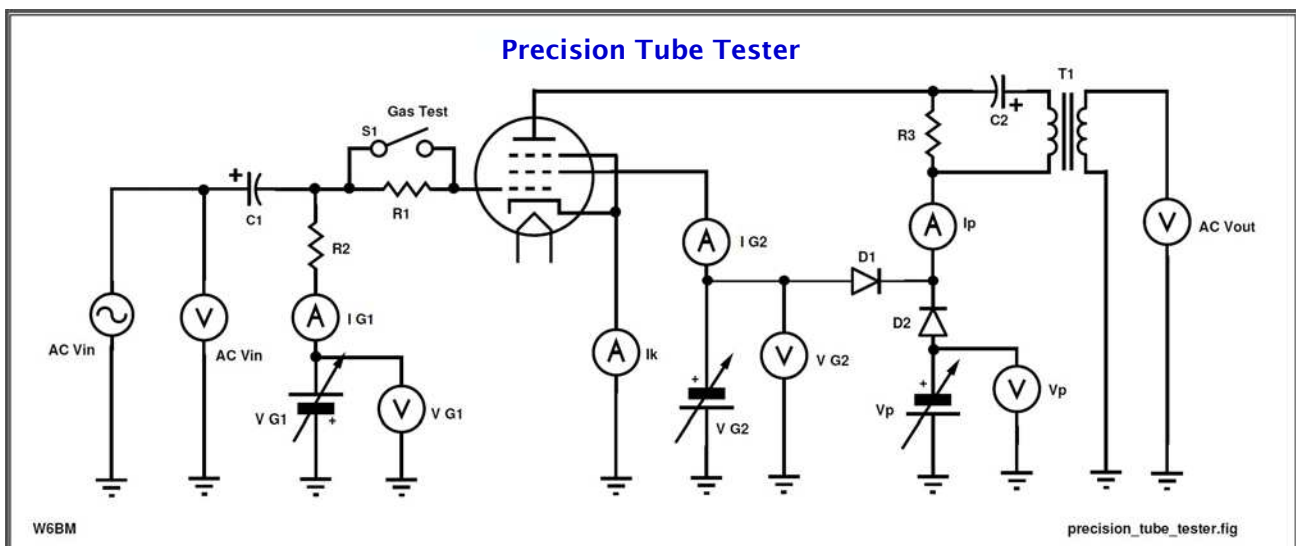

An AC signal  $V_{in}$  is mixed with a DC bias and applied to G1, the control grid. The transconductance of the tube is the ratio of the variation of the plate current by the variation of control grid voltage.

The AC component of the plate current causes an AC voltage component to be generated across R3 in the plate circuit.

To measure this voltage independent of any small variations in the DC plate voltage supply, a transformer is placed across the resistor, and a large-valued capacitor eliminates any DC in the primary of the transformer. In addition, the secondary of the transformer permits the AC measurement to be made with a ground reference, enhancing noise immunity.

The diodes in the screen grid (G2) and plate circuit form a wired-OR circuit that prevents the screen grid voltage from exceeding the plate voltage to prevent accidental over dissipation of the screen. This circuit can be switched out.

The rest of the diagram shows the position of the voltage and current measurements, and the insertion of a high-value resistor in series with the control grid that serves as a gas test. Gassy tubes, when a large value of external resistance is inserted, show a significant change in DC plate current.

## A Practical Circuit

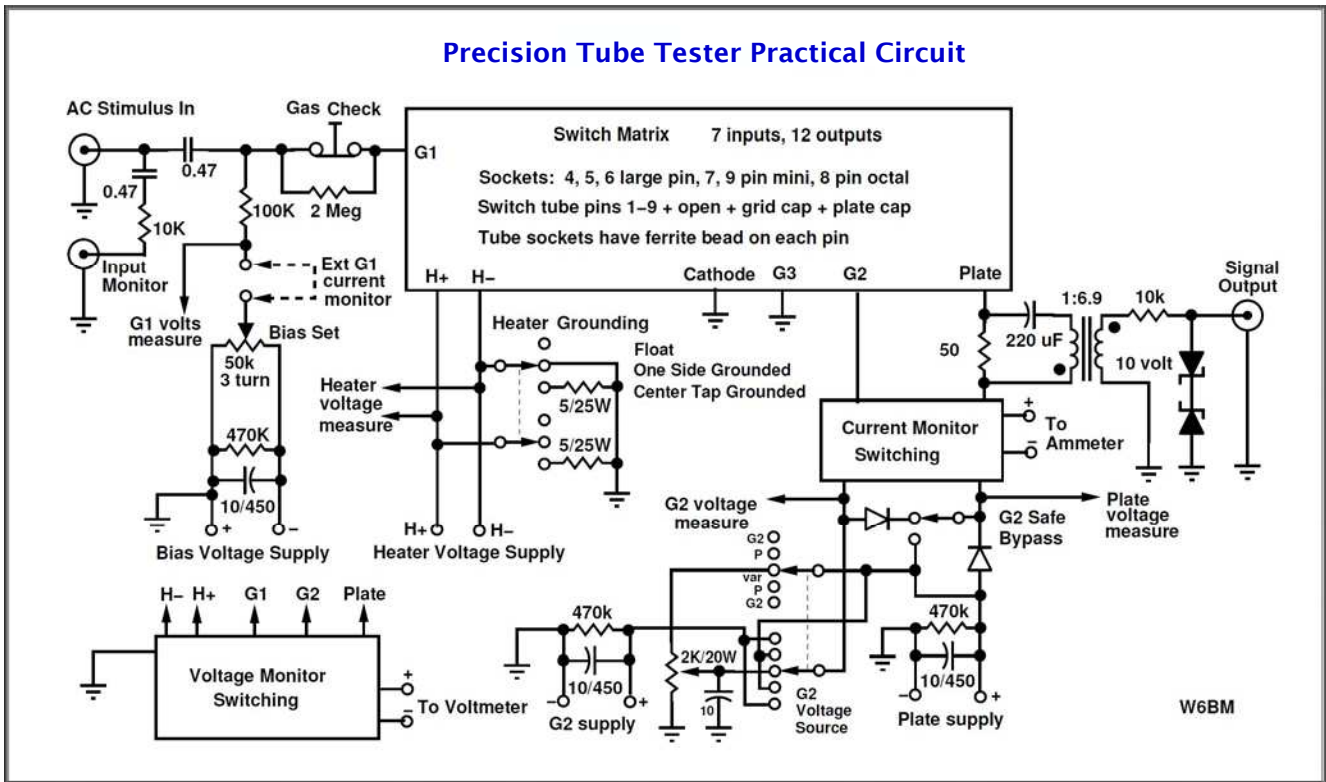

The circuit follows the ideal circuit closely. An AC stimulus signal is returned at the Input Monitor jack and applied to the control grid through a 0.47 uF capacitor, with a 100Kohm grid return resistor to a multi-turn Bias Set potentiometer. I have found that some variable power supplies do not regulate well near small output voltages, so the negative bias supply is set to a stable value, and the actual bias level set by the control on the tester. Since the bias is an important parameter to set for several different operating conditions, it is convenient to have that control immediately available.

The heater circuit provides three configurations: one side of the heater or filament can be grounded for AC heaters or the negative side of DC heater power supply with the Heater Grounding switch in its center position.

For a filament tube using a floating power supply, a 5-ohm, 25 watt resistor is switched in from each side of the filament to ground, providing a 2.5 ohm cathode bias resistor. This center-taps the floating power supply, providing minimum hum for an AC supply for a filament tube, and puts the ground at the center of the filament for either AC or DC supply.

The “float” position of the heater switch removes all grounds and allows the user to use his own filament power configuration, and allows heater-cathode leakage to be measured.

The use of the Heater Grounding switch has an important implication for filament-type tubes. A filament tube will respond differently depending on whether the ground bus is in the middle of the filament or at one end. This is discussed in the Appendix.

The screen grid is supplied by a power supply separate from the plate power supply, or from the plate power supply itself, or from a voltage divider off the plate supply. If the screen grid voltage significantly exceeds the plate voltage, the power dissipation of the screen may exceed the tube ratings. So a “G2 safe” circuit is included with two diodes that in the safe condition, the plate voltage is kept to at least the screen voltage. The switch disables this if not desired for special tests.

Switches are provided to connect an external voltmeter to measure the heater voltage, bias, screen and plate voltage. Another switch inserts an external ammeter in the screen or plate current path. These meters must be floating.

The AC signal generated in the plate circuit is produced across a 50 ohm wire-wound power resistor. This low value has many benefits. The AC voltage generated in the plate circuit will be relatively small, keeping the tube within its linear operational condition. In addition, the 50 ohm plate load is in parallel with the plate resistance of the tube itself. Tubes with very low amplification factor may have a low plate resistance, and as it is in parallel with the plate load resistor, it may compromise the accuracy of the measurement. The low 50 ohm value of the plate resistor minimizes the shunting effect of tubes with low plate resistance. Some testers, such as the AN/USM-31 take this effect into account for tubes with low amplification factor.

The low value of the load resistor allows tubes with a high DC plate current to be safely tested, as the dissipation of the load resistor will be low, so a thermally-induced change of resistance will be minimized.

And finally, the calibration accuracy of the tester depends on only two components: the value of the load resistor, which was measured with a 4-terminal resistance measurement, and the turns ratio of the coupling transformer.

The measurement of the coupling transformer is facilitated by using an audio generator that also has a 50 ohm output impedance so the transformer can be measured with a similar set of terminating impedances.

The transformer used is a small fully-encapsulated audio input transformer. It exhibits a flat response in the audio range, and has a resonance at about 50 kHz. The tests are carried out at 1 kHz, well within the range of the transformer. The voltage step-up ratio is measured to be 6.90 at 1 kHz over a large range of frequencies around 1 kHz with a 1 Megohm load on the secondary. The measured value of the plate load resistor is 50.75 ohms.

## Measurement of Transconductance

For a transformer step-up voltage ratio of  $N = 6.90$ , and plate load resistor value  $R = 50.75$  ohms, the transconductance, measured in microMhos is

$$G_m = \frac{10^6}{NR} \frac{V_{out}}{V_i} = 2856 \frac{V_{out}}{V_i}$$

where  $V_{out}$  is the AC voltage from the output transformer, and  $V_i$  is the stimulus AC voltage applied to the control grid.

For the values used in the tester the constant  $10^6/NR$  in the equation is 2856 microMhos. The output voltage and input (stimulus) voltage are measured in the same set of units, their ratio calculated, multiplied by 2856, gives the transconductance in microMhos.

It is possible to display the transconductance numerically by selecting a “magic” value of input voltage  $V_i$ . For example, if the input voltage were 0.2856 volts, then the equation above is  $G_m = 10000 V_{out}$ . If the output voltage were 0.602 volts the transconductance  $G_m$  would be 6020.

## Construction

The tester was constructed entirely out of the W6BM junk box parts.

The unit was built with a detachable top plate that eased the wiring of the tube sockets. The top is connected to the base unit through an 8-pin Jones plug.

Six tube sockets are included: 4, 5 and 6-pin big-pin, 7 and 9-pin minis, and an octal socket. Two pin jacks are provided for grid and plate caps.



Tube tester front panel.



Tube tester top panel.

Seven 12-position rotary switches select the pins for the seven tube elements: heater + and -, cathode, control grid, screen grid, suppressor grid and plate. The cathode and suppressor grid are always grounded.

The seven selector switches select one of 9 tube pins, and the other three positions select “none”, grid cap and plate cap.

To ease the construction, each switch position wire used the standard resistor color code. Each color terminated on a terminal strip contact, which was then wired to a pin on the tube sockets.

This picture to the right shows the wired selector switches awaiting the wiring of the tube sockets.

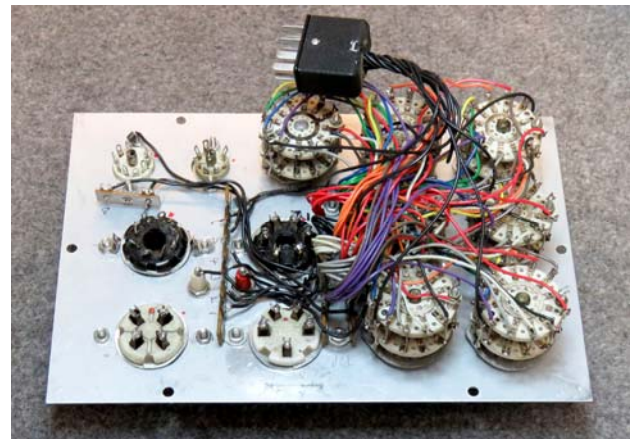

Seven 12-position switch assembly.

A ferrite bead is included at each tube socket to prevent parasitic oscillations. An earlier version without the beads occasionally showed a 50 MHz oscillation with particularly hot 6L6s. After installation of the beads, no instabilities have been observed for any set of operating conditions. The permeability of the beads is unknown, but high permeability with high loss at VHF would be preferred.



Use of ferrite beads.

Shown on the next page is a setup with four digital meters, an audio generator to the right, and an oscilloscope monitoring the input and output signals. The heater, control grid, screen grid and plate power supplies are not in the picture. The front panel graphic was prepared and printed on peel and stick paper and laminated behind clear tape.

The digital meters show the input and output AC voltages, 224 and 476 millivolts to the 6L6 in the tester. The voltmeter selector switch selects the bias setting, 14 volts, the current selector switched to the plate meter shows 65.2 mA plate current.

With these values, the transconductance of the 6L6 in the socket is 6068 microMhos. The test frequency is 1 kHz, with 250 volts on the plate and the screen. At these operating parameters, the tube manual value of the 6L6 transconductance is 6000 microMhos.

## Observations

One objective in constructing the tester is to evaluate the effect of overdriving the grid of small-signal amplifiers, the “12AX7 effect”. The variation of the drive stimulus is not generally available, even in laboratory testers. Shown on the next page are the author’s AN/USM-31 (military version of the Weston 686-C9), and the Daystrom/Weston CA-1630 laboratory tester owned by CHRS.



Test set up.

These two testers are laboratory-quality, somewhat dated, but allow complete selection of the operating parameters. They do not provide adjustability of the stimulus voltage, which is 1 volt RMS 60 Hz in the AN/USM-31 in the 3000  $\mu\text{Mho}$  scale, 0.5 and 0.2 in the 6000 and 15000 scales. The plate load resistor shunting effect of tubes with low plate resistance (low- $\mu$  tubes) is accounted for by selecting the plate load resistor based on tube amplification factor. The CA-1630 uses a 0.1 volt RMS 10.5 kHz stimulus and a very low value of plate load resistor. These testers provide a transconductance measurement reproducibility within 3-5% of each other for the same tubes. The reproducibility of a measurement of the same tube taken at different times is usually within about 2 percent. Agreement with the AN/USM-31 is better than 5 percent.

The accuracy of both testers relies on the stability of several components, including the gain stability of the internal amplifiers and several values of resistors.

The precision tester is totally passive, containing only one resistor and transformer in the signal path. All power supplies, AC and DC voltmeters and ammeters are external. Used with a digital oscilloscope, which displays the values of the stimulus and output, the actual waveform can be observed.



Laboratory grade tube testers: AN/USM-31 (Weston 686-C9) on the left, and Daystrom/Weston CA-1630 on the right.

Measurements have been taken of several varieties of tubes: 6J5 triodes, 12AX7 small-signal amplifiers, 6L6s and 6SK7 pentodes.

For a lot of eight 12AX7s tested, observing the output waveform on an oscilloscope, tube nonlinearities at a grid stimulus signal much less than the DC grid bias were evident. Here are two tubes, each with a low transconductance measurement, with the same stimulus and similar output but very different amounts of second-harmonic distortion.

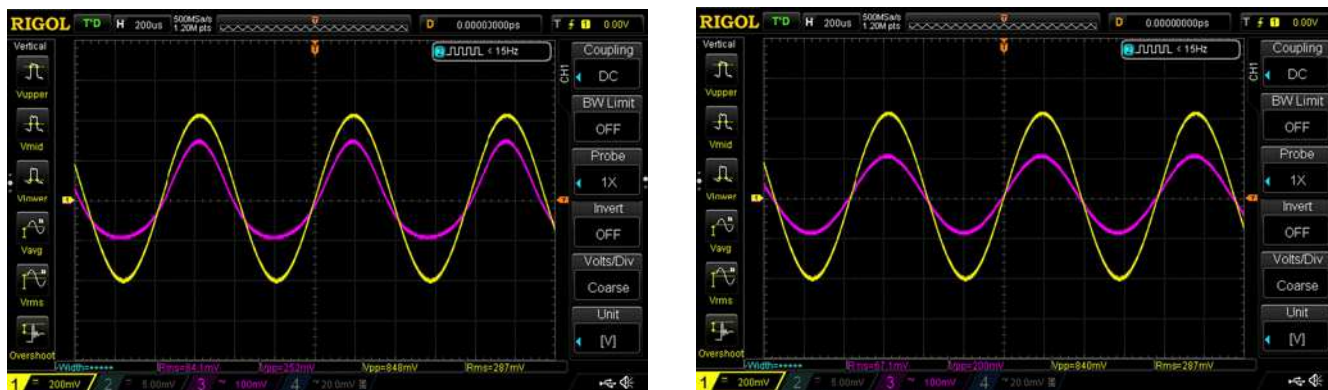

Waveforms of two tested 12AX7 tubes (right & left) compared. The input signal is the yellow trace, the output is the purple trace.

Indeed, it could be that these two tubes might sound very different even though they demonstrate about the same transconductance.

## Conclusions

A tester was designed and constructed that provides a window and control into all the operational parameters, including the stimulus voltage and measurement of the distortion products, using the FFT function of the oscilloscope, or using an external distortion meter.

The differences in distortion levels was a surprise, and not indicated by the other testers. This tester is highly extensible, as the data set is the tube manual. Using tube manual parameters, the tube being tested is set up with the listed voltages, and the operating currents and transconductance then measured and compared.

The most complex part of the construction was wiring the tube pin selector switches. If an unused tester were available to be cannibalized, the tube sockets, switches and filament transformer could form the basis of a precision tester, as the rest of it is passive with few additional components. The original meter could even be converted to the voltmeter and ammeter function.

I thank Gilles Vrignaud for several suggestions that improved this note.

## Appendix — Testing Filament Tubes

In filament tubes, the heater is also the emitter, there exists a potential drop from one end to the other of the filament, the bias along the length of the filament varies, and thereby the effective amplification of the tube.

The RCA R-10 tube manual calls for the grounded (negative) side of the filament supply be connected to the ground reference which is the positive side of the grid bias supply. This means that at the other (positive) end of the filament, the potential difference between that end of the emitter and the control grid is larger, equivalent to operating at a higher bias level.

However, most tube testers apply AC to the filament. These testers provide a center-tap, either on the transformer, or with a small resistor from each side of the filament to the positive terminal of the bias supply. This places the center of the filament at the ground reference.

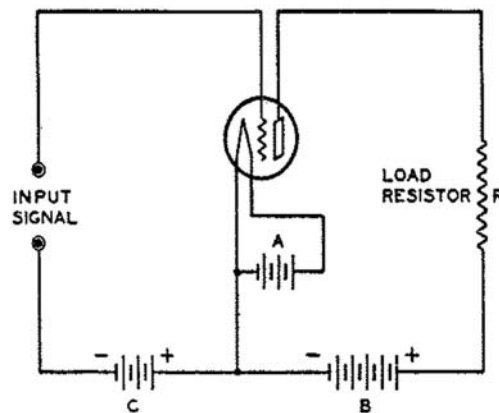

Typical filament tube bias arrangement. Image from RCA RC-10 tube manual.

This can result in an incorrect measurement of the transconductance of the tube.

For a specific example, the R-10 tube manual lists the following defining characteristics for the 201A:

Filament voltage	5.0 volts
Grid Bias	-9.0 volts
Plate voltage	135 volts

At these operating values, the bogie tube parameters are:

Plate current	3.0 mA
Amplification factor	8
Transconductance	800 microMhos

The bias arrangement of the tube is as shown as follows:

The bias battery, in series with the AC signal source establishes the potential of the control grid, point D in the figure.

The ends of the filament are A and C, the center of the filament is at point B.

With a DC filament supply the 201A is biased with one end of the filament at ground and the other end at the positive side of the filament power supply.

With a center-tapped either AC or DC power supply, neither end of the filament is at ground; instead the center of the filament at point B is effectively at ground. This will result in a different operating mode with a modified effective bias. The tube operational characteristics will be modified.

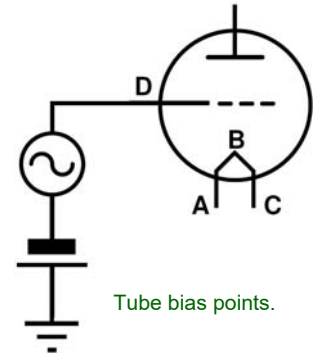

Four arrangements of filament and bias connections are investigated: two with one end of the filament at ground, and two with the center of the filament B at ground, each with an different DC bias.

The voltages at each A, B and C are listed, as well as the voltage difference from each of these points to the grid, point D. The plate current in mA and transconductance  $G_m$  in microMhos is also measured. The voltage from the center of the filament to the grid, B to D, is a significant measure of performance. Cases 1 and 3 have one end of the filament grounded, 2 and 4 have the center tap effectively grounded.

Case	Point A	Point B	Point C	Bias	A to D	B to D	C to D	$I_{plate}$	$G_m$
1	+5	+2.5	0	-9	-14	-11.5	-9	2.67	780
2	+2.5	0	-2.5	-9	-11.5	-9	-6.5	4.84	919
3	+5	+2.5	0	-6.5	-11.5	-9	-6.5	4.58	921
4	+2.5	0	-2.5	-11.5	-14	-11.5	-9	2.79	782

Case 1 and 2 are with “normal” bias and asymmetric and symmetric filament voltage. Note that the measured case 1 plate current and transconductance are similar to the listed bogie values for the 201A. Case 2 shows a larger plate current and transconductance. This is due to the fact that the average filament-to-grid voltage is reduced by one-half the filament voltage, or 2.5 volts. In case 1, the middle of the filament is 11.5 volts positive with respect to the grid (B to D). In case 2, this voltage is reduced to 9 volts.

Case 3 shows that the measured parameters are similar to case 2 with one end of the filament grounded, and the bias adjusted down by 2.5 volts to -6.5 volts. Here, the voltage between the center of the filament and the grid is the same as in case 2, -9 volts. Case 3 looks like case 2, with the same plate current and transconductance with the bias in case 3 reduced but with the same filament configuration as case 1.

Case 4 shows the measured parameters with the center tap of the filament at ground potential and the bias increased by one-half the filament voltage, or up by 2.5 volts to -11.5 volts. Here, the voltage between the center of the filament and the grid is the same as in case 1, -11.5 volts. The measured plate current and transconductance are very similar to case 1. This represents the correct bias voltage when the center tap of the filament supply is grounded.

This is important, as most tube testers measure the tube characteristics using a center-tapped AC filament supply. If the “tube manual” set parameters are used, which were developed with one end of the DC-powered filament grounded, the measured plate current and transconductance will be high and inaccurate.

In addition, a center-tapped 5 volt AC filament supply was also tried. When one end was grounded, a strong 60 Hz modulation of the 1 kHz test signal was present at the output. But when the center-tapped of the filament transformer was grounded, only a small 120 Hz amplitude modulation of the much larger 1 kHz signal in the plate circuit is observed. With a bias of -9 and -11.5 volts, the plate current is 4.84 and 2.82 mA, and the transconductance is 929 and 784 microMho, as in cases 1 and 2.

The same 201A was measured with three other testers owned by the author: an AN/USM-31 industrial tester, the navy version of the Weston 686-C9, which applies DC to the electrodes and AC the filament using resistors to provide an effective center tap and applies a small 60 Hz test signal to the control grid.

The tube was also tested on a TV-7/U and a Hickok model 600, both using the Hickok bridge circuit form measuring transconductance with rectified AC on the plate and a DC bias on the control grid.

The AN/USM-31 with the nominal values of bias and plate voltage show the same plate current and transconductance as case 2 above, as the AC filament supply is center-tapped by a small-value resistors. With a bias of -11.5 and -9 volts, the measured transconductance are similar to cases 4 and 2 above.

The manual that comes with the AN/USM-31 tester specifies that the bias be set at -9 volts with a plate voltage of 135 volts, the RCA R-10 tube manual values. This would be in error, as the correct value of bias to test this tube is -11.5 volts with a center-tapped filament supply. This industrial tester must be used with caution, and the corrected bias value used, or the tube characteristics would be reported as too optimistic.

The TV-7U, with the listed setup applies a bias of -12.6 volts, but the plate voltage is half-wave rectified AC, so it is difficult to equate the DC voltage used in the previous two testers. The transconductance is measured as 810 microMhos, in reasonable agreement with the correct value. So it is apparent that this tester modifies the bias setting to accommodate the center-tapped AC voltage on the filament to obtain an approximately correct transconductance reading.

The Hickok 600, with a center-tapped AC filament transformer, does essentially the same thing. Here, with the listed setup, the DC bias is -14.7 volts and the transconductance measurement gives 700 microMhos. This lower value is consistent with the higher bias voltage.

## Analysis

Testing filament tubes requires knowledge of the configuration used by the tester of the ground point of the filament supply and the adjustment of the bias voltage used to give the correct measured value of the transconductance of the tube.

The AN/USM-31 laboratory-grade tester manual gives the wrong value of bias for this tube, and gives the wrong value of transconductance and plate current for these settings. The settings are right out of the RCA R-10 tube manual without any thought of the filament supply configuration.

Other testers get around this by changing the bias voltage, which is generally not known to the user unless actually metered with external instruments. The actual plate voltage used by the Hickok versions is unknown and variable during the test cycle, so a correct value of bias voltage is not easy to calculate.

---

## The Author

Dr. John Staples, W6BM, designs and builds particle accelerators at the Lawrence Berkeley National Laboratory. He received his Extra Class ham license and First Class Radiotelephone and Radar licenses in 1958. Besides being an avid collector of vintage electronics, he has been a passionate motorcyclist for over 50 years.





## KDIA: Power to the People

By David Ferrell Jackson



*Oakland radio station KDIA – known as “Lucky 13 Boss Soul Radio”—was born in the 1920s and left the airwaves in the 1990s, and is the recipient of the Legendary Station Award from the Bay Area Radio Museum and Hall of Fame for 2018. This is a look back on its long and colorful history.*

It may be hard to imagine, but radio in the San Francisco is well over a century old at this point.

If you can imagine yourself on this date one-hundred years ago, without your smartphone, without Wi-Fi but with the 1918 equivalent – that fanciful high-tech bit of magic called “the wireless” – then you may be considering a trip to downtown Oakland, to a small shop operated by the Warner brothers, where you can buy the parts required to build yourself a wireless receiver or, if you were truly adventurous, an actual, working spark transmitter.

These Warner brothers, Stafford W. and Eugene N., were unrelated to Harry, Albert, Sam, and Jack, their counterparts of later (and somewhat greater) Hollywood motion picture fame, but nonetheless had a significant and lasting impact on the history of entertainment and community involvement.

Some forty years after Stafford and Eugene launched their fledgling radio enterprise near Oakland’s Lake Merritt, their business had grown from selling parts to fellow hobbyists to operating a small continuous-wave amateur station which, in turn, grew into a commercial broadcasting station that spawned its own “Radio Village” and developed into a strong, substantial voice for the Eastbay’s emerging African-American community in the post-World War II era.



Stafford Warner circa 1940s

The station, which began as experimental 6XAM in 1920, and was licensed commercially as KLS in 1922 before becoming KWBR (for “Warner Brothers Radio”) in 1945, eventually attracted the attention of Egmont Sonderling, a German immigrant who had built a small but powerful regional network of stations at mid-century that programmed mostly rhythm-and-blues music – the genteel term for what was generally known in the industry as “race records” – directed toward a predominately black audience.

Sonderling bought KWBR in July 1959 for \$550,000 and re-christened it as KDIA in September of the same year to mirror its pioneering sister station, WDIA in Memphis, Tenn. With Walter Conroy installed as its general manager, KDIA rapidly refined its schedule and, by the middle of 1961, was broadcasting news, music and other programs throughout the day aimed specifically at African-American listeners.

### **The Golden Years: KWBR**

Into the late 1940s, KWBR, operating at 1310 kilocycles on the AM dial as an independent station without network ties, relied on blocks of recorded music and local entertainers for its programming, much of it targeting transplanted listeners tuning in for a taste of home. A representative sample from the *Oakland Tribune*’s radio log from January 1948 finds KWBR’s schedule filled with “Corriere del Mattino,” “Mi Rancho,” “Voice of Portugal,” and “Echo of Italia,” along with standard fare such as “Musical Echoes,” “Luncheon Lounge” and “Demand Performance.”

Soon, however, programs entitled “Sepia Serenade” (featuring early R&B records) and “Negroes In The News” (hosted by Tarea Hall Pittman, West Coast regional director of the NAACP and a pioneering women’s and civil rights activist) began showing up on the station’s schedule among the Italian, Portuguese and Spanish-language shows, and began taking up larger and larger blocks of time. By 1957, the KWBR schedule was dominated by R&B disc jockeys “Big Daddy” Don Barksdale, Bouncin’ Bill Doubleday and Bob Parker.

The Oakland-born Barksdale was a considerable presence in the Eastbay throughout his life: not only as a radio and TV personality but as an entrepreneur who owned night clubs and a beer distributorship, promoted musical acts and records. He also happened to be the first African-American player to be named an all-star in the National Basketball Association in 1953, shortly after the league lifted its color barrier.

Barksdale also won a gold medal as a member of the U.S. men’s basketball team at the 1948 Olympic Games in London, becoming the first black player to make the team and the first to win gold. Two years later, he made his television debut, presenting “Sepia Revue” on San Francisco’s nascent KRON-TV (Channel 4) while hosting his own nightly radio show on Oakland’s KROW (960 kc.).

Bouncin’ Bill, who was born John William Doubleday, also played rhythm-and-blues records on KWBR – often covering lengthy daily shifts in the morning and afternoon, weekdays and weekends included – and promoted live shows at local clubs.

What many listeners didn’t know, however, was that Bouncin’ Bill was actually a white man who, much like Jumpin’ George Oxford, his southern-born (and also white) counterpart at San Francisco’s KSAN (1450 kc.), simply loved R&B music.

Both Barksdale and Doubleday were inducted into the Bay Area Radio Hall of Fame: “Big Daddy,” who passed away in 1993, was enshrined in 2007, while “Bouncin’ Bill,” who served as the station’s general manager in the early 1970s, entered BARHOF in 2011. (In addition, Barksdale was inducted into the Naismith Memorial Basketball Hall of Fame in 2012.)

During more than a quarter century as “Lucky 13” KDIA, the station’s hip “Boss Soul” sound was guided by an exceptional roster of air talent that included Chuck “Buggs” Scruggs, Bob Jones, Johnny Morris, Sly Stone (before he became even more famous as leader of The Family Stone), John Hardy, Bill Hall, Bob White, Rosko



George Oxford circa 1958.

(William Roscoe Mercer), Roland Porter, Wally Ray, Brother Louis Freeman (who was the station’s news director and hosted gospel music programs on KDIA), Sam Skinner, Marlon Scott (Alonzo Miller), Barry Pope, Alvin John Waples, Lady P.J. Ballard, Doug Cass and Al Moreland.

As former R&B competitor KSAN began to fade, even the stalwart Jumpin’ George Oxford (BARHOF ’06) eventually crossed the Bay to become KDIA’s morning man.

But the most notable of KDIA’s many stars was Belva Davis, who, after several years as a young print journalist for local black publications, began her radio career as the only female voice on the air at KSAN, then moved to KWBR as traffic manager in its advertising department – a role she quickly parlayed into her own one-hour “women’s show” on weekdays, with a two-hour edition on Saturdays.

From that humble start, Miss Davis embarked on a legendary career that included anchoring the news on KPIX-TV (Channel 5) and KRON-TV, and hosting the weekly “This Week In Northern California” on KQED-TV (Channel 9). In addition to



Belva Davis (KDIA).

being elected into the Bay Area Radio Hall of Fame in 2007, she was inducted into the National Academy of Television Arts and Science’s Gold Circle in 2013 in recognition of her fifty years of distinguished work in local TV.

### The Origin Story: 6XAM

The Oakland-based Warners didn’t intend originally to become pioneers in the wireless business, nor did they intend to build a station to primarily serve black listeners; instead, they were quite content to run their family’s grocery and mercantile store.



Belva Davis with another on air personality, Jeannie Blevins.

However, as the fledgling and almost-entirely experimental radio “hobby” began to blossom as World War I ended, Staff and Eugene couldn’t help but becoming intrigued.

They began by building their own simple wireless receivers – “radios,” such as they were – then branched out to building small, primitive transmitting devices from plans shared in hobbyist magazines; those early works led them to setting up a few shelves in the family store with radio parts, which led, in turn, to their decision to build their own amateur radio station, which became licensed as 6XAM in 1920.

On September 21, 1921, the Warners made their first voice transmissions over 6XAM, which impelled them to take the next big step. By this time, the Radio Division of the Department of Commerce had already begun issuing its first handful of licenses for commercial broadcasting; by the end of 1921, a total of 25 of the licenses would be issued, with seven of them going to stations in the Bay Area.

As 1921 came to a close and 1922 began, the Warners began piecing together a new, more substantial station at the First Baptist Church at 2201 Telegraph Avenue in Oakland, near their family store. Satisfied that their facility was ready to take to the airwaves, they applied to the Radio Division and were granted a limited commercial broadcast license on Friday, March 10, 1922, along with being assigned KLS as their callsign.

The Warner brothers wasted no time, putting KLS on the air immediately with a brief and impromptu welcoming program sent out via their 250-watt scratch-built transmitter, operating at 360 meters – the single wavelength assigned to all commercial stations in the United States at that time.

By July 1922, KLS had embarked on a regular schedule of programs and opened an auxiliary studio in the *San Francisco Daily News* building across the Bay, offering daily bulletins with the latest news. Still sharing the single broadcast channel with other local stations in January 1924 at 360 meters (about 833 kiloHertz on today’s AM radio dial), KLS operated from 11:30 a.m. until 1 p.m. on Sundays, and from 8 to 9 p.m. on Fridays.

Later in 1924, KLS was assigned to a “Class A” frequency at 1190 kilocycles, then was moved to 1200 kilocycles early in 1926. Owing to financial constraints, the station reduced its operating schedule in 1927 to one broadcast: the Sunday morning church services of the First Baptist Church – an easy enough program to put on the air, as it emanated from the same edifice that housed its transmitter.

By June 1927, KLS was moved to 1220 kilocycles by the Federal Radio Commission – which had been spun off from the Department of Commerce – then was given the 1440 kc. spot in the FRC’s nationwide frequency reallocations in November 1928. As the year ended, Stafford Warner took on an expanded role in managing the station, returning it to an extended broadcasting schedule.

He would guide KLS through the Depression years, during which many other small hobbyist-built stations across the United States fell silent, and the station not only survived but became a sustainable enterprise; so much so that Staff had plans drawn up for a “Radio Village” at 327 21st Street in Oakland, just off Harrison Street – a \$30,000 enclave of eleven rustic “cottages” intended for retail businesses as well as the new, modern studios of KLS.

In November 1936, the renamed Federal Communications Commission granted a construction permit allowing KLS to move its facilities to the proposed Radio Village,

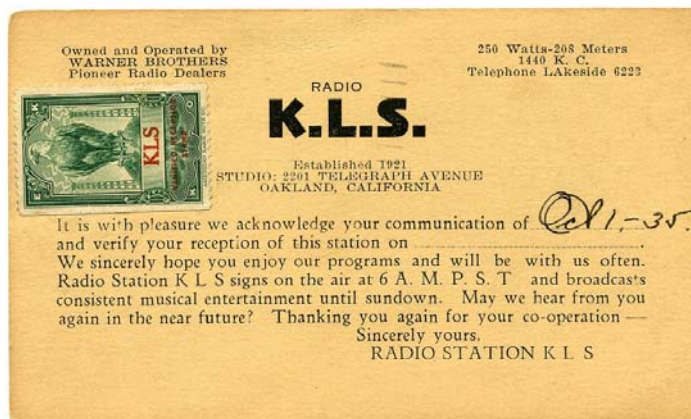

KLS QSL cards. Above from 1935, on the right from 1944.

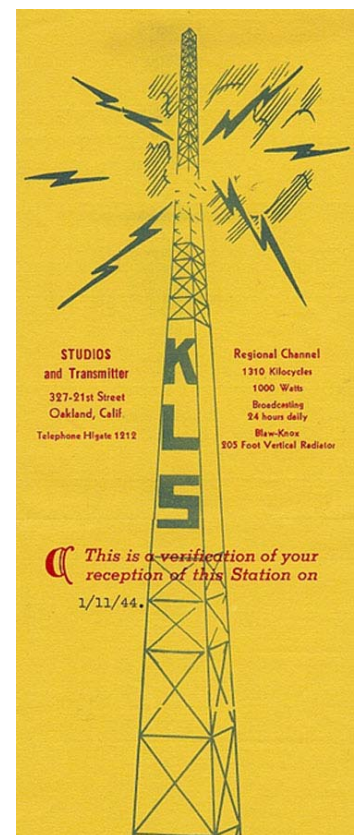

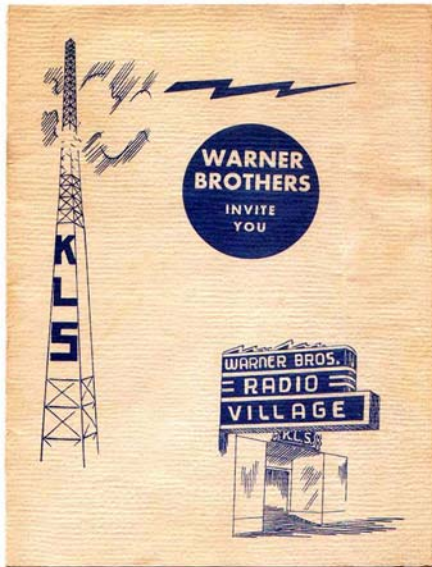

KLS Radio Brochure cover on left , interior on the right.

which would also house the station's new 179-foot Blaw-Knox transmitter tower, from which it would broadcast its 250-watt signal from yet another new frequency, 1280 kilocycles.

On March 15, 1937, KLS began transmitting from the new facility, then welcomed the public with a gala grand opening on Saturday, April 10, 1937, hosted by new KLS production manager Wellington Morse. Tributes were presented by other Bay Area radio stations, including the local NBC stations, KPO and KGO; the Columbia network's new affiliate, KSFO; plus KFRC, KLX, KGGC, KYA, KROW and KRE. Visitors were invited to tour the KLS studios and

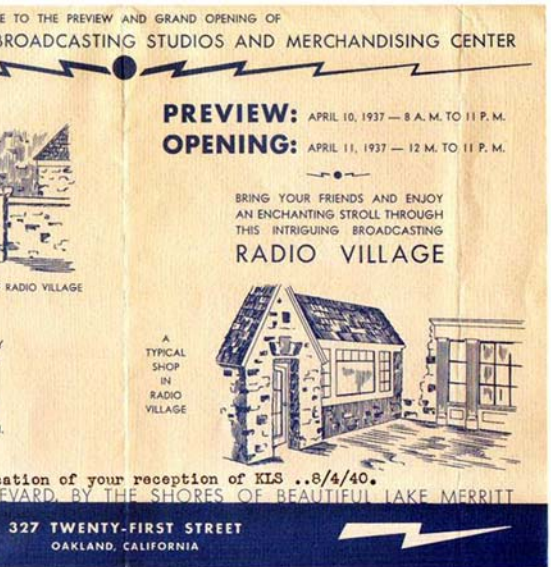

KLS invitation (1937).

the retail shops, which included a beauty salon, furniture store, a dry cleaner, a tea room and, of course, a radio parts and supply store.

Wellington Morse was an old hand in the industry upon his arrival at KLS. Morse had immersed himself in radio since his youthful days with experimental 6XAK and commercial KFWH, which he built in Chico, Calif., his hometown, back in the 1920s. He would remain at the Warner brothers' station in Oakland through the early 1950s.

In the major NARBA Treaty frequency reallocations of March 1941, under which nearly every AM station shifted its dial position, KLS found its final resting place at 1310 kilocycles. By the end of the year, KLS added another 26 feet to its transmitter tower, capping it at 205 feet above Radio Village, while raising its power to 1,000 watts and instituting an around-the-clock schedule, becoming one of the first stations in Northern California to broadcast 24 hours a day.

On May 8, 1955, the station's co-founder and longtime guiding spirit, Stafford Warner, died at the age of 63. In the ensuing months following his brother's death, Eugene Warner assumed control of the station, then soon made plans to sell it; after fielding several offers, the station was placed in trust in 1958, pending its sale to the Sonderling stations group.

**WDIA** AMERICA'S FOREMOST ALL NEGRO STATION Memphis  
50,000 Watts

welcomes another  
**SONDERLING INDEPENDENT NEGRO STATION**

SAN FRANCISCO—OAKLAND **KDIA** (formerly KWBR)

The highest-powered, and ONLY Full-time Negro Program Station delivering a primary signal to each and every Negro Community in the 7 Bay Counties.

stars the **"FABULOUS FIVE"**

<b>DON BARKSDALE</b>	All-American and Olympic Basketball Star, the Bay Area's most popular Negro personality.
<b>BOUNCIN' BILL</b>	Effervescent, lovable, Rhythm and Blues expert, who has an uncanny ability to pick the music listeners prefer most.
<b>SWINGIN' DEACON</b>	The Bay Area's Greatest Disc Jockey, returning after an absence of 3 years to delight his audience with the antics they like so well.
<b>JEANIE</b>	Adorable, and gorgeous Mistress of Ceremonies of "Jeanie's Women's World."
<b>TED BYRD</b>	Beloved throughout the Bay Area for his inimitable manner of presenting spiritual and gospel programs.

THE GREATEST ARRAY OF NEGRO TALENT EVER PRESENTED IN THE WEST. PROGRAM ENTERTAINMENT TO CONFORM WITH 1959 DYNAMIC RADIO.

**KDIA** guarantees **TOP NEGRO RATINGS**  
1st in the afternoon 1st  
Perfect Coverage  
Super Market Merchandising

OAKLAND SAN FRANCISCO

EGMONT SONDERLING, President and General Manager—WALTER CONWAY, Manager  
National Representatives:  
Edward Howard & Co., New York • Chicago • Atlanta—E.R.A. Inc.—Los Angeles  
SONDERLING STATIONS—WDIA, Memphis—WOPA, Chicago/Oak Park—KBIA, San Francisco/Oakland

BROADCASTING, September 14, 1959  
KDIA announcement (9/4/1959).

Sonderling embarked on numerous improvements to KDIA's physical plant, most notably abandoning the aging Radio Village studio and transmitter facility in downtown Oakland and moving to a new site adjacent to the Bay Bridge Toll Plaza. The move was accompanied by a five-fold increase in KDIA's power to 5,000 watts. (The old Radio Village was soon razed and a parking garage for nearby Kaiser Center was erected on the site.)



KDIA studios at the Bay Bridge Toll Plaza (circa early 1970s).

**SEVEN STRONG PERSONALITIES SELL THE SAN FRANCISCO BAY AREA NEGRO MARKET ON KDIA!**

**GEORGE OXFORD**  
6:30 - 9:00 am, 12:00 noon to 1:00 pm - Monday through Saturday  
George has been the highest rated personality on the Negro radio for 14 years. Morning - Rhythm and Blues music, local Negro and wire news, time and temperature. Noon - Rhythm and Blues music, wire and local Negro news.

**BROTHER LOUIS FREEMAN**  
9:00 am to 12:00 noon - Monday through Saturday  
Only Negro Gospel personality on the air at these housewife listening times. Gospel music, biblical passages and prayers, church news. Includes 15 minutes of Mahalia Jackson.

**DON BARKSDALE**  
1:00 to 3:00 pm - Monday through Saturday  
"Big Don" is known nationally as a "Hall-Of-Fame" basketball star. Known locally as a radio personality for twelve years by almost every Negro listener. Rhythm and Blues. Includes segment of national Negro news. Top rated Negro program of this time period.

**ROLAND PORTER**  
3:00 - 4:00 pm - Monday through Saturday  
KDIA Program Director. Leads throughout Negro Pulse, strong general ratings. Rhythm and Blues format. A three minute spotcast of race results. Sports news every half hour, voiced by KDIA sportscaster in a separate feature within the program. 6:00 - 6:30 pm features highly popular "Blues" program.

**ROSKO!**  
9:30 - 12:00 midnight - Monday through Saturday  
Formerly a leading daytime personality on another local Negro station. Rosko sells it all in a record time, set the flow right into and from the music. Fast paced from start to finish. Follows KDIA's audience participation "Sound Off" program.

**TIME FOR JEANIE**  
12:00 midnight - 1:00 am - Tuesday through Sunday  
Ranked above competitive radio personalities in independent agency survey. Begins the all night Jazz program on KDIA. Features jazz music exclusively - frequent interviews with jazz artists.

**WALLY RAY**  
1:00 - 3:00 am - Wednesday through Sunday  
Nationally known as one of the outstanding radio personalities in the jazz field. The Late, Late Show - Jazz music exclusively - frequent interviews with jazz artists.

THE AWARD **KDIA** WINNING STATION

KDIA promo sheet (circa 1960s).

ADAM MUSIC PENT  
905 Cosmos Street  
Napa, California  
Phone 294-7907

**1310 KDIA TOP 25 LUCKY THIRTEEN**

POS	TITLE	ARTIST	LABEL
1.	It's All Right	Impressions	ABC Paramount
2.	Cry Baby	Garrett Mims	United Artists
3.	Cry To Me	Betty Harrison	Jubilee
4.	Elephant Walk	Donald Jenkins	Cortland
5.	Strange Feeling	Billy Stewart	Chess
6.	Mickey's Monkey	Miracles	Tamla
7.	Cut You A-Loose	Ricky Allen	Faith
8.	It's Too Late	Wilson Pickett	Double L
9.	Walking The Dog	Rufus Thomas	Star
10.	Busted	Ray Charles	ABC Paramount
11.	I'll Take You Home	Drifters	Atlantic
12.	Part Time Love	Johnny Taylor	Galaxy
13.	He's Down On Me	Betty Green	Clara
14.	Chinese Checkers	Booker T & MG's	Stax
15.	Louie, Louie	Paul Revere	Columbia
16.	I-I Can't Be First	Dee & Tina Turner	Sonja
17.	Heat Wave	Martha & Vandellas	Gordy
18.	Two Tickets To Paradise	Brook Benton	Mercury
19.	Two Sides	Etta James	AFRO
20.	Misty	Lloyd Price	Double L
21.	Any Number Can Win	Jimmy Smith	Verve
22.	Pull The Covers	Tran Sisters	Imperial
23.	Just A Little Bit	Jerry Butler	Vee Jay
24.	Shake A Tail Feather	S. Dintons	One-Derful
25.	Sometimes You Gotta Cry	Bobby Bland	Duke

**DIA "Diamond" Of The Week**  
Major Lance  
Okeh

**DIA "Diamonds"**

You're No Good	Bobby Everett	Vee Jay
You're No Good	Des Dea Warwick	Jubilee
Tobacco Road/Blues To A...	Lou Rawls	Capitol
Come Back	Johnny Mathis	Mercury
Crazy Bout My Baby	Marvin Gaye	Tamla
In Love With You	Johnny Taylor	Derby

SURVEY NO. 153  
October 4, 1963

KDIA music survey (10/4/1963).

## The Grand Finale: KDIA

Although the 1960s and 1970s found KDIA at its height, the onset of the 1980s found it moving past its prime. On March 25, 1980, KDIA, its Memphis sister station WDIA and the other Sonderling properties became part of the vast stable of outlets owned by Viacom International in a \$32-million merger.

Three years later, in December 1983, Viacom disposed of both KDIA and WDIA, selling them to the lawyer and media entrepreneur Ragan Henry in a deal valued at \$24.5-million; Henry, in turn, one year later transferred control of KDIA to Adam Clayton Powell III, son of the fabled New York congressman.

On Monday, December 10, 1984, at 9 p.m., after a long on-air farewell, KDIA and its popular R&B format left the airwaves, replaced by new KFYY call letters, from new studios at 100 Swan Way in Oakland, with a fresh all-news format that put it in direct competition with the two local powerhouse news outlets, KCBS and KGO.

It didn't last. On April 9, 1985, after only four months on the air and with ownership unable to make payroll and in default on a \$4-million loan from Aetna Insurance, KFYY fell silent. In July 1985, the FCC granted permission to Henry to revive the station as KDIA; it returned to air with an "Urban MOR" format in October of the same year.

For several years, KDIA clambered along, playing "Hits 'n' Oldies" aimed at the audience which had grown up with the station. Henry defaulted on his loan from Aetna in 1992, and the station was sold for \$1.6-million in November of that year to a group of investors led by California State Assembly speaker (and future San Francisco mayor) Willie Brown and then-Oakland mayor Elihu Harris.

Brown and Harris moved KDIA to new studios at 384 Embarcadero West in Oakland; it remained there after being sold yet again in June 1995 to James Gabbert, who had previously owned San Francisco's landmark K101 AM and FM and, at the time, owned KOFY (1050 kHz.) in San Mateo. Having paid \$3-million for KDIA, Gabbert instituted several improvements, switching the station to AM Stereo and boosting its power to 20,000 watts – all the better to hear its "Urban Oldies" music format.

This, too, would not last. Gabbert agreed to sell KDIA to ABC for \$6.25-million in December 1997, with the station becoming KMKY – “K-Mickey” – to go with its new satellite-fed Radio Disney children’s format. (It is a widely-held belief that the personable Gabbert also had regular guest-hosting appearances on ABC’s powerhouse KGO [810 kHz.] written into the sale agreement.)

In the past few years, while still bearing the KMKY call letters, the former KDIA became the property of the affiliated Akal Broadcasting and Radio Punjab, which has operated the station since 2015 as “Radio Mirchi, The Spice of Life,” via its studios in Milpitas.

And what about the old KDIA call letters? Since 1998, when they were discarded from the 1310 spot on the AM dial, they have resided on 1640 kHz., on the Christian Talk station operated by Baybridge Communications in nearby Richmond, California.

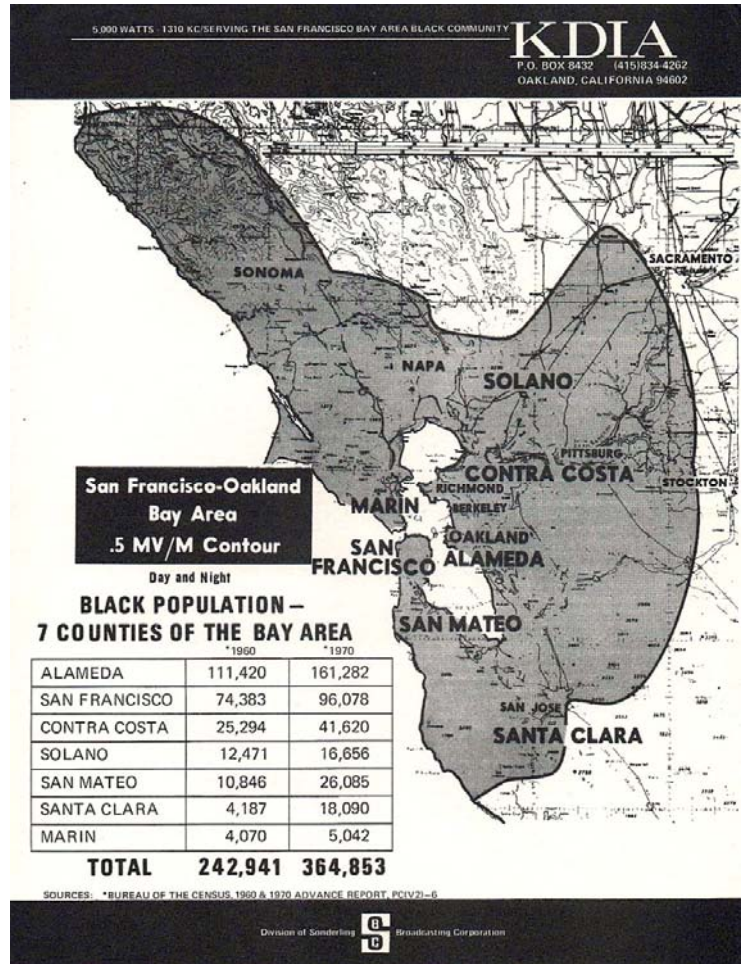

KDIA coverage map (circa 1970).



KDIA music survey (Dec. 1973).

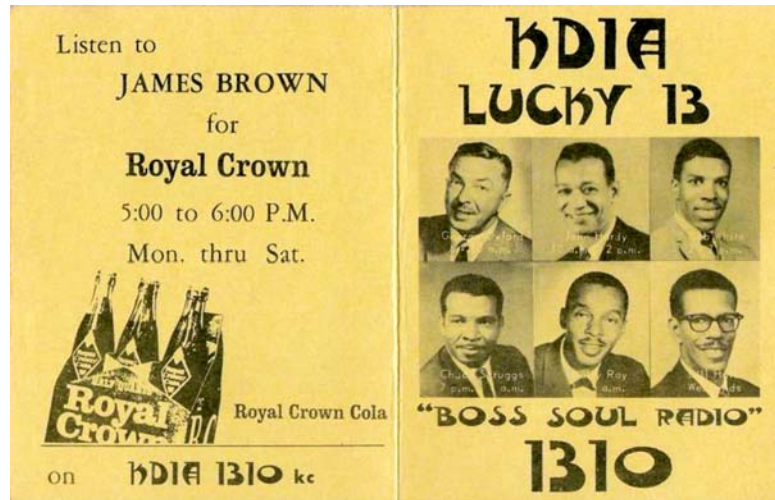

KDIA music survey (June 1966).

David Jackson is the founder and executive director emeritus of the Bay Area Radio Museum and Hall of Fame, and a member of the board of directors of the Broadcast Legends, based in San Francisco. ◇

# A Radio Odyssey (Part 3) — The Science Museum in London, U.K.

By Bart Lee

Bart Lee recently traveled to Europe and visited communications-related museums. The first two visits were chronicled in the prior issue. This is the third article of his visit in the UK.

The Editor

Most, if not all, technical museums feature the work of the scientists, engineers, industrialists and designers of their nation. In that regard, the Science Museum in London is fortunate that Great Britain pioneered almost all of the modern world.

The Science Museum devotes much of its exhibit space<sup>1</sup> to “The Information Age.” This theme introduces itself as:

“... tell[ing] the story of 200 years of information and communications technologies. The gallery is arranged into six ‘networks’: Cable, Broadcast, Exchange [telephones], Constellation [satellites], Web and Cell. Each area presents the technologies and infrastructure alongside the extraordinary stories of the people who created, used and were affected by each new wave of change.”

The dominating object on central display is the entire inductive tuning apparatus of the high-powered VLF station GBR. The sun never set on the reach of its signals. These massive, multiple coils of litz wire tower over the rest of the items on display, at six meters tall and eight meters in length (Fig. 1 & 2). A video display shows it in situ (Fig. 3). GBR, located in Rugby, England took to the ether in 1926 at 16 kHz. It helped knit together the British Empire and then the Commonwealth. Inasmuch as such VLF signals could penetrate the oceans, GBR also played a unique role, especially after Britain put nuclear weapons on submarines, in “Communications, Command and Control” (Fig 4, a video displayed map; note the Rugby station at the bottom left inset and the antenna inductor in the fourth inset).



Fig. 1: GBR tuner.



Fig. 2: GBR tuner.

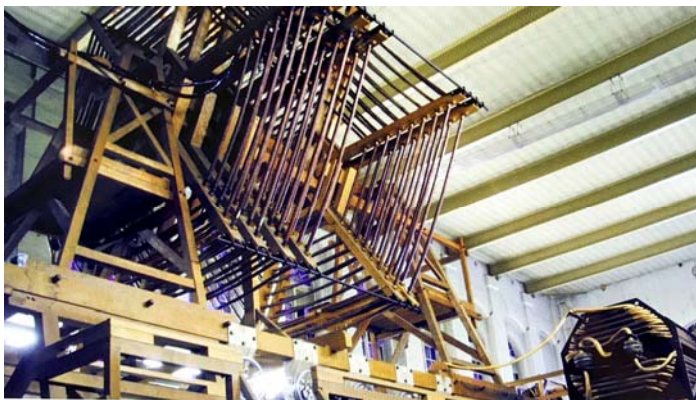
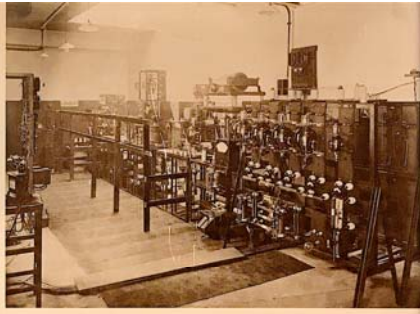

Fig. 3: GBR aerial tuning inductance coils at Rugby Radio. Source: BT Heritage & Archives.



Fig. 4: Graphic of the GBR Network.



**Marconi 1.5 kW transmitter, used by the BBC London station 2LO, 1922–25**

On a foggy November night in 1922, the words 'This is 2LO calling' announced the arrival of the BBC. 2LO, the BBC's first transmitter, took words and music from studios in Savoy Hill near The Strand and transmitted them to listeners at home. At this time the BBC's reach was limited to London.

**Fig. 5: Marconi 1.5kW transmitter, London.**

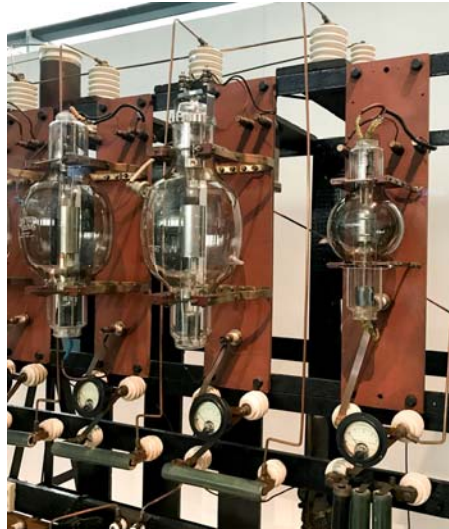

**Fig. 6: Close up of Marconi valves.**



**Fig. 7: Braille crystal receiver.**

The Science Museum complements its objects of interest with “tactile models.” While such models improve the experience of the visually challenged, they each present a different and useful perspective on the object. With respect to GBR, one can look down on it as well as touch it. The small model (1:10 scale) may actually provide a better sense of the immensity of the object. The interpretive text also provides another vantage point, in this case the metaphor that its “six coils, resemble a giant spider’s web.” It further notes: “The coils tuned the aerial system to a very low frequency. Rugby’s signals carried small amounts of information but they travelled around the curvature of the Earth.”

In the area of broadcasting, displays two early and whole Marconi transmitters, one medium wave AM and the other shortwave AM. The banks of big Marconi “valves” glow with an industrial beauty all their own (Figs. 5 & 6). While these are static displays, once again by reason of their sheer size, the industrial quality of even early broadcasting appears. Home radios could be as small as crystal sets (many of which are on display), but industrial might brought the music and voices into British homes. A tactile model for the blind of a crystal set also presents interpretive text in Braille as well as dial markings (Figs. 7 & 8).

Many of the displays of consumer radios and televisions also include recorded sound, and often video. The blind as well as the sighted benefit from these mini-soundscapes. These audio displays also isolate the sound so as not to interfere with the stories that nearby displays tell.

Although highlighting British invention, the Science Museum gives other nationals their due. For example, it honors Lee DeForest and his Type-D tuner (Fig. 9). It

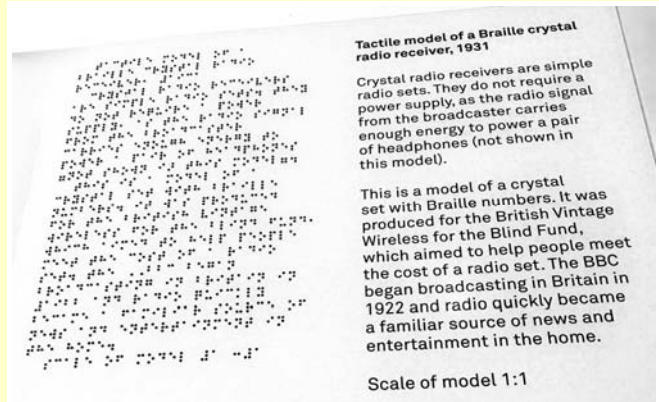

**Fig. 8: Tactile model of a Braille crystal receiver.**

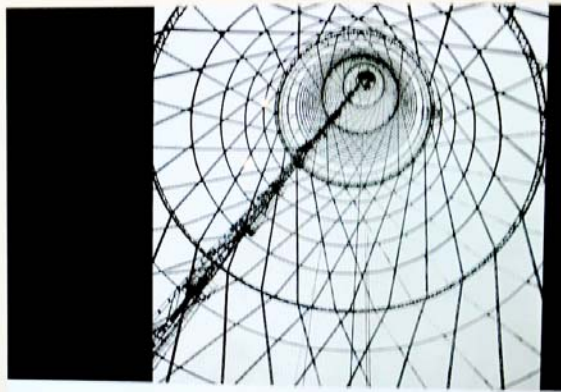

**Fig. 9: Lee DeForest Type-D tuner.**



## History of the radio tower

In post-revolutionary Russia radio was perceived to be a vital tool for communicating with the people. Alongside the new state plan for electrification, Vladimir Lenin believed radio could form a significant part of the plan to modernise the country, and create the right conditions for economic and social reconstruction.



Shabolovka Tower, 1919–22.  
Source: Professor Dr Rainer Graefe



Fig. 10: History of the hyperbolic Soviet Russian antenna tower (above).  
Fig. 11: A large model of the antenna (right).

also provides a very large model of the famous hyperbolic Soviet Russian antenna tower in Moscow (Fig. 10). A video display tells the story of Chief Engineer Vladimir Shukhov's accomplishment. (Fig. 11; The Popov Museum features a smaller model of this tower).

British military radio appears but with less emphasis than civilian developments; for example, the World War Two tank radio Wireless Set No. 19 (shortwave and VHF) and a photo of it in use (Figs. 12 & 13).

In connection with radio's early development, the displays feature many unique Marconi items from his first days in England, noting that Marconi's trial-and-error methods were still dominant in 1899 with respect to hand wound coils (Fig. 14). The museum acknowledges that Marconi's mercury detector (fig. 15), the device that snatched the three-clicks from Cornwall in Newfoundland in 1901, was indeed invented by



Fig. 12: WW II Wireless Set No. 19 tank radio.

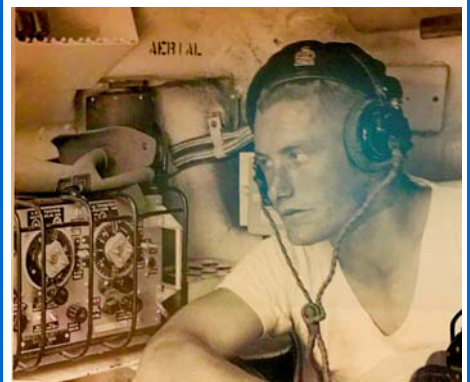

Fig. 13: A tank radio in use.

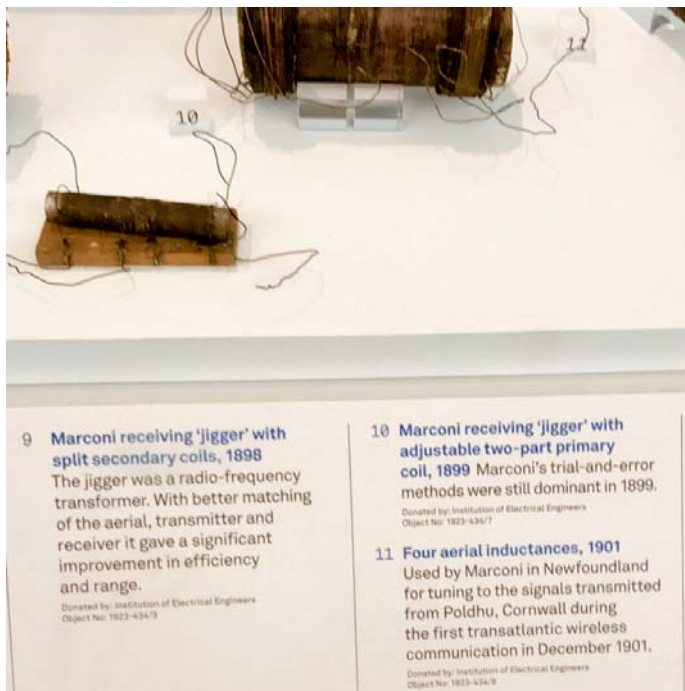

Fig. 14: Marconi coils.

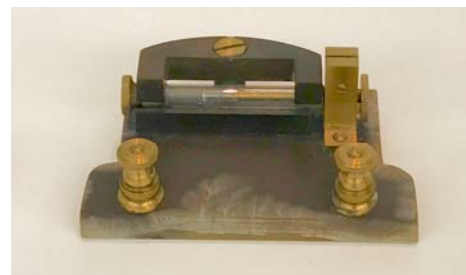

Fig. 15: Marconi mercury detector.



Fig. 16: Fleming valve.

### 9. Fleming's Diode Valve 1904

The invention of the thermionic valve in 1904 by John Fleming at the Marconi Company was a significant development for electronics and radio communication.

The first transatlantic radio transmissions of 1901 threw up a significant problem: how to detect the incredibly weak radio signals at the receiving end. Fleming, inspired in 1904 by a 'sudden and very happy thought', turned to modified experimental filament lamps which he had investigated earlier, and found that they detected the high-frequency signals.

His invention was a diode, the first in a line of devices which were to be a mainstay of electronics well into the solid-state era.

Source: J A Fleming. Inv. 1925-814

### 10. De Forest's Triode Valve 1907

The triode valve is a switch device and an amplifier of electrical signals which became a key component of radio, television, radar and computer systems, before the development of the transistor in 1947.

The first triode valve was patented in 1907 by American wireless pioneer Lee de Forest and called the Audion. It was initially used as a radio detector, like Fleming's diode valve of 1904, but its true potential was not realised until 1912 when it was incorporated into a circuit which could amplify audio and radio signals.

Source: University College. Inv. 1955-143

Fig. 18: Interpretive text for both tubes.



Fig. 17: DeForest Audion.

the Indian scientist Jagadis Chandra Bose. It also honors Bose for his extensive late 19<sup>th</sup> Century radio work in microwaves and the invention of a galena solid-state detector in 1904.

Fleming's early work on vacuum devices, especially the Fleming Valve of 1904, has pride of place among the many exhibits of vacuum tubes (Fig. 16); so, too, a very early DeForest Audion (Fig. 17). The associated interpretive text is quite fair (Fig. 18 -- but without mentioning the no doubt apocryphal tale that when Fleming heard about DeForest inserting a "grid" into his valve, he exclaimed "I wish I'd thought of that!").

The museum's current displays also honor pre-Marconi investigators, such as Oliver Lodge. He used a "gap coherer" in 1889 to detect nearby electromagnetic pulses (Fig. 19). In 1894, Lodge tried iron borings as coherer material (Fig. 20)

Various other early detector types are displayed, to the delight of the passing electronic antiquarians. These included the 1902 Muirhead rotating steel-wheel-in-a-pool-of-mercury (Fig. 21): "This detector was more reliable and sensitive than any other known at the time." These presentations show how truly experimental was the work that led to modern communications.

For the collector of radios, many interesting British radios appear, *e.g.*, the Pye Cambridge International PE-80 (1953), long wave, broadcast band and short wave, in an elegant cabinet with an impressive dials by wavelengths and city, plus a Tunemaster band indicator (Fig. 22). Inasmuch as Queen Elizabeth was crowned in 1953, several displays focus on this period. These include early British television, which broadcast the coronation ceremonies.

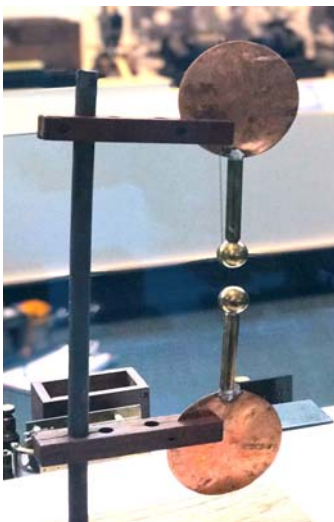

Fig. 19: Gap coherer.



Fig. 20: Coherer using iron filings.

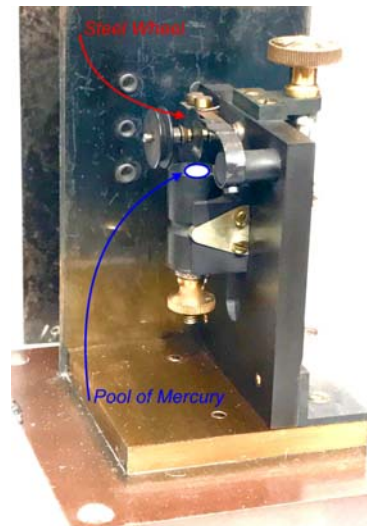

Fig. 21: Mercury coherer.



Fig. 22: Pye Cambridge International PE-80 (1953).



Fig. 23: Replica of a 1930's mechanical televisor.

British mechanical television provides a prologue. One display features a “home made 30 line televisor” of the rotating wheel type, noting that “This equipment was built from scratch and on a limited budget by an 18-year-old enthusiast’ (Fig. 23).

Of course the story of the Information Age must relate the failure and success of communications with respect to the RMS *Titanic* in 1912. A replica of the wireless room and related equipment shows the then state of the art equipment

(Fig 24). The equipment, unlike the vessel, worked exactly as it should, but the inadequate standards for communication at sea in this early period cost many lives.

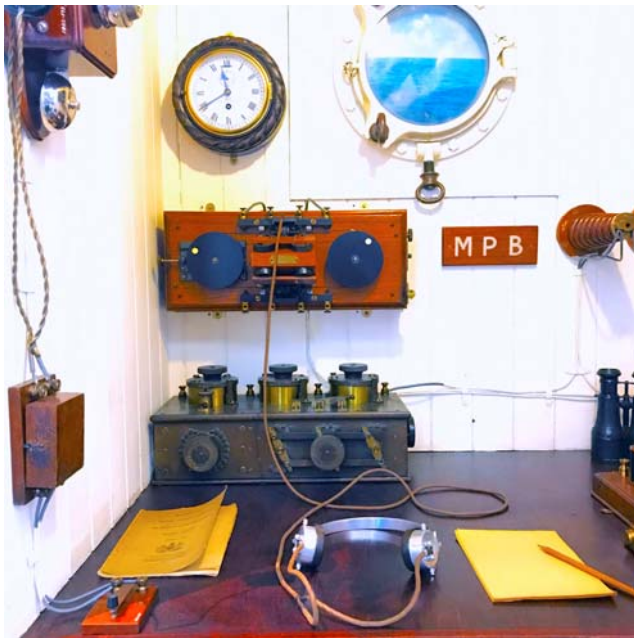

Fig. 24: Replica of RMS Titanic wireless room.

The Science Museum’s interpretive materials and comprehensive scope are first rate. One innovation is the employment of roving interactive guides, offering a photo opportunity<sup>2</sup> (Fig. 25). The museum’s devotion to accuracy and its comprehensive and international scope are unparalleled. And it’s free.



Fig. 25: Friendly and knowledgeable.

**Notes:**

1. The ground floor features the first British steam engines and the earliest locomotives. An upper floor devotes itself to rocketry and satellites. Two cafeterias are open, as well as a nice bookstore. The Natural History Museum is next-door and the Victoria and Albert Museum of British culture is across the street.
2. Some years ago, on the ground floor, I puzzled over of the very first steam locomotives because I could not figure out the drive mechanism. A courteous voice behind me called out: “There’s bits missing!” He was a curator and we enjoyed a pleasant and instructive conversation. He also took me up to see the Marconi mercury detector, which had been placed in a special exhibit. I likely would not otherwise have found it.



# Internet Radio Project

By © Brett van Zuiden

## Origins

On a biking trip with my dad in late 2016 we got to thinking about what other experiences you could create by adding an ultra-small computer to a traditionally nondigital product. My dad suggested we could retrofit an old radio, and we both got pretty excited about the project, especially if we could retain as much of the original look and feel of the radio.

Borrowing the physical interface concept that I liked from a prior project, I built the experience around "tuning" between different "stations" - turning to a specific portion of the dial would activate specific programs. For example, you could tune to a certain station to stream a favorite Pandora station, or play a Spotify playlist, or anything else a computer can do, like reading out your calendar for the day.

## About The Radio

We purchased a vintage Philco 38-12 compact table model radio from eBay. The radio was originally sold in 1938; it had been restored to great condition and worked great. We selected this one because it looked great and fit well on a desk (about the size of a large toaster). I also wanted a radio with just two knobs - one for volume, and one for tuning - to keep the interface as simple as possible. This same concept could retrofit just about any radio, but I liked the look of this one, and loved the vintage sound from the vacuum tube amplifier. All retrofit modifications to the radio can be easily reversed to put the radio back to original design.

The radio is designed to sound and feel as authentic as possible. When tuning between stations, static is blended into the audio stream proportional to your distance from each station, and the radio keeps track of timing to maintain the illusion that a station has "kept playing" while you were away, just as with actual radio. The audio output from the computer is fed through the radio's original vacuum tube amplifiers to give a pleasant warmth to the sound. The radio's original tuning condenser is the input mechanism, so changing stations has the same satisfying mechanical resistance as the original. The combination of these small touches makes a big difference in matching people's intuitive expectations of how the radio "should" work.

Inside the radio is a Raspberry Pi 3 model B, along with some additional ICs to read in the currently selected station. One of the first versions I made used a C.H.I.P. (a proprietary single-CPU computer development kit), but I switched to a multi-core computer because the various programs running concurrently on the single C.H.I.P. CPU caused some stuttering in the streaming audio. Fortunately, the radio has a continuous power source (it's plugged in to the wall), and there was ample space in the radio to fit a computer, so when choosing components I didn't have to worry about size or power consumption.



Philco 38-12 beautifully restored.

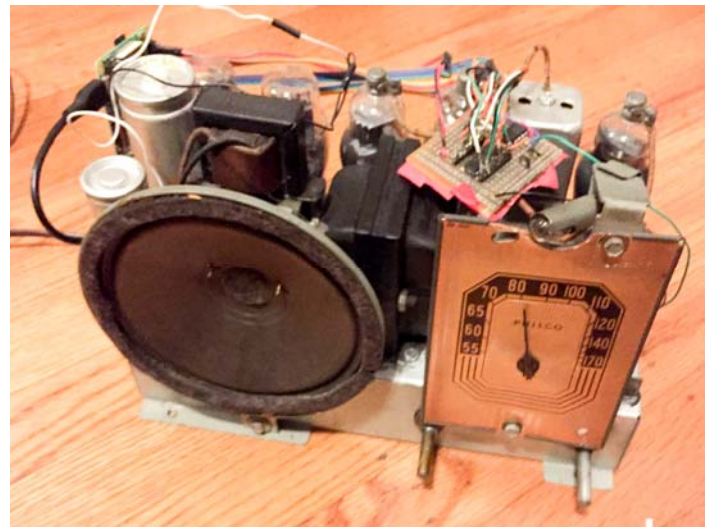

Philco 38-12 with added circuitry for internet radio.

I configured the radio with 15 distinct radio stations - most of them play music off of different Pandora stations, but I also added a “old timey radio addresses” and “old timey sports broadcasts,” because listening to things like Martin Luther King’s “I Have a Dream” speech on a vintage radio is spine-tinglingly cool. One of the stations also is set up with AirPlay, so you can stream music from your computer or phone.

Personally, I love that I can just turn on the radio, turn the dial to match my mood, and hear music I like. The analog controls make the radio simple to use - there are no lists to scroll through or buttons to tap, but in exchange, you don’t have as much control. It’s been interesting to hear people ask “Can you skip to the next song?” - people have gotten accustomed to being able to play any song any time, rather than listening to whatever is currently playing on the radio.

## Building The Radio

After getting the radio, I was pleasantly surprised that it worked well right out of the box. It took me a bit to find an AM radio station that was powerful enough for the radio to pick up - I ended up using a makeshift antenna to get a better signal - but once I did the radio sounded great. My first goal was to get a basic lay-of-the-land and figure out where I was going to hook up the computer, so I slid the internals out of the case and was surprised to see a tangled mess of wires and components.

The circuitry in the radio was old technology, but new to me; it looked nothing like the black-ICs-on-green circuit board that I was used to from other projects. It took me a while to understand what all the components were and how they were wired. The voltages are much greater than in digital circuits ranging from -30V to 290V, I knew I would have to take precautions in connecting the audio without frying the computer. I spent a few days with the radio’s schematics with my oscilloscope until I had a fairly good understanding this radio design.

The basic design of a radio is to take AM radio waves, demodulate them to get the original audio signal, amplify that signal, and play it. Given this, my plan was to connect the computer audio output with an AM modulator, feed it into the radio circuit, and call it a day. I spent quite some investigating this approach to develop an AM circuit design and attempted to feed it into the radio, but I wasn’t able to get anything to play.

After many frustrating false-starts, I connected the AM-modulated output to a part of circuit I hadn’t tried yet, and was able to hear a recognizable song through the speaker, although the sound quality was terrible. I kept trying different setups for the AM-modulation. Finally I decided to connect the sound source directly by stripping a standard 3.5" audio cable, soldering one channel to the cathode of the 1st audio amplifier, and soldering the ground from the 3.5" audio cable to the radio's ground. This connection could be unsoldered and removed to return the radio to original. Eureka! The sound came out crystal clear.

Since I had found a way to deliver audio directly into the radio’s amplifier circuit, I didn’t need to deal with modulating the signal. Now that I could now play audio, I wired up a USB wall-wart to the radio’s power supply, plugged in the C.H.I.P., and had a basic proof-of-concept.

## Playing Pandora via the radio

With the audio output now taken care of, I turned my attention to how to read the input from the dial. I wanted to use as much of the original internals as possible, so I decided to try to read the capacitance of the radio’s tuning condenser as an indicator of the dial’s current position. To do this, I simply clipped the wires connecting to the tuning condenser and instead fed them to a timer-based capacitance reading circuit (see Philco 38-12 schematic on next page). The leads can be re-soldered to their original connection points to restore the radio to it's original function if so desired. Capacitance is very difficult to read directly, so I connected the capacitor to a 555 timer configured as an astable oscillator. As the dial turned, the capacitance increased or decreased, creating a corresponding change in the frequency output of the 555 timer circuit. Initially I tried to use the computer to read this frequency, but even using hardware interrupts, the accuracy of the timing was terrible. So instead I fed the frequency into a CD4040B 12-bit counter, which I polled every 100ms. Reading 12 counter bits took a lot more wires, but was able to read the frequency - and therefore capacitance, and



Philco 38-12 under-chassis circuitry.

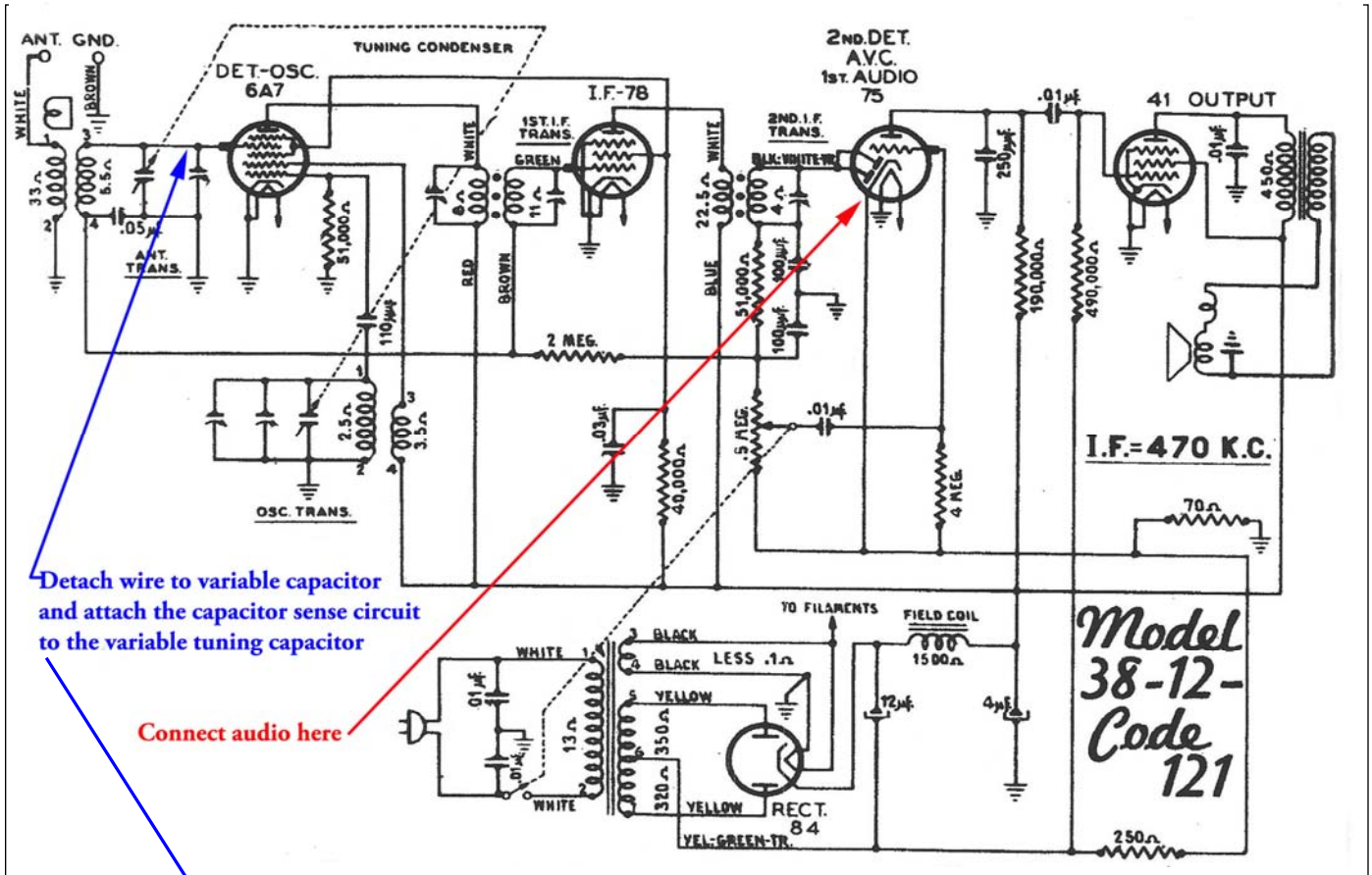

Schematic of the Philco 38-12 radio.

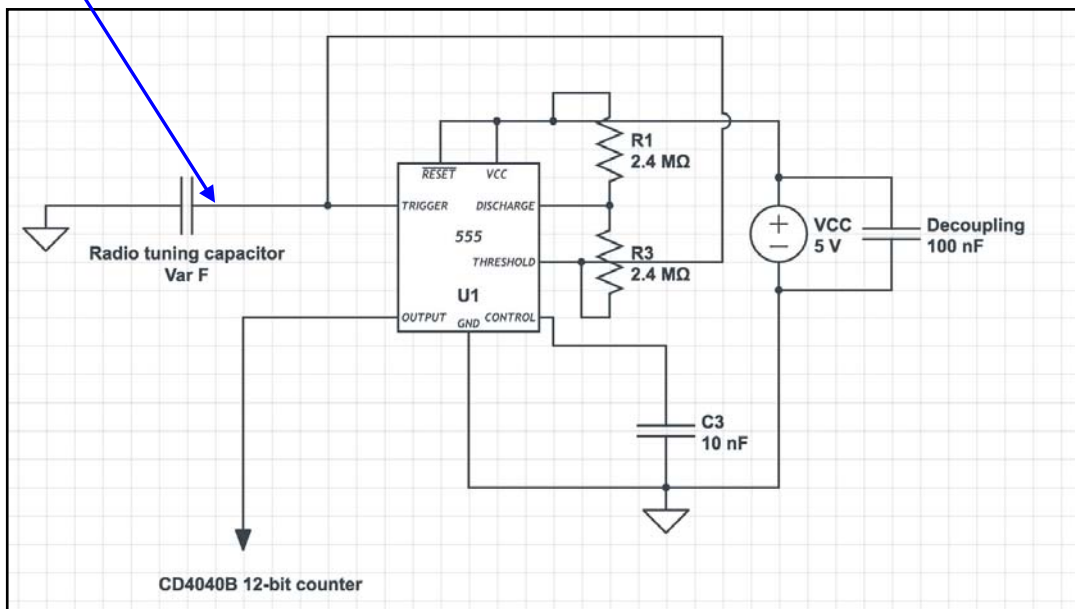

Circuit for sensing the dial position of the radio tuner capacitor. Blue arrow shows where connection from 555 trigger is made to the radio variable tuning capacitor.

therefore dial position - much more accurately. Once the prototype was working, I built the small capacitance-reading circuit onto some proto-board and hooked it all together. I could now run a simple python program on the computer to play different songs based on the dial position.

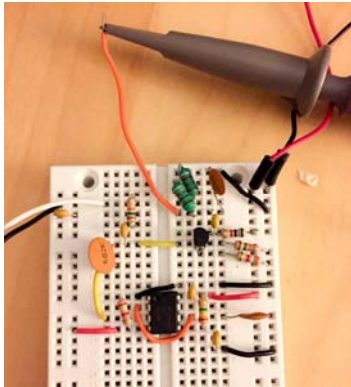

Capacitor sense circuit prototype.

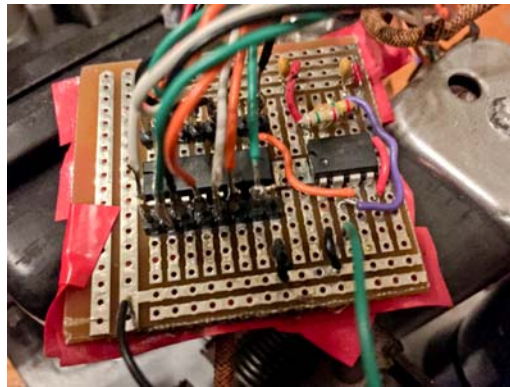

Finished capacitor sense circuit.



Connection of capacitor sense circuit to variable tuning capacitor.

## Changing songs by turning the dial

At this point, the hardware was essentially completed, and I focused on the software. Again, lots of experimentation, at one point having to essentially start over when I switched to using the Raspberry Pi instead of the C.H.I.P. because I needed multiple cores. Ultimately, I ended up with the following setup:

- The main program is a python application that reads the GPIO to determine the current tuner position, and loads the corresponding station. When activated, each station selects a song from its designated folder on the computer, and signals to mpg123 to play the specific file. When the station changes, the program signals to mpg123 to play a different song, and keeps track of the offsets to make it seem like the stations continued to play even when you moved to a new station.
- A second mpg123 process plays a file of pink noise on loop, which the main program fades in or out to create the illusion of static space “in between” stations. Each station had a frequency that was its center point, and static was blended in as you moved away from that center point towards a different station. I found cubic easing felt best.
- A background process runs a modified version of Pianobar (a Pandora console app) that keeps the content of the different folders “fresh” with music from different Pandora stations. Originally I was going to stream directly from Pandora, but that wouldn't have been able to seek/pause/play music with the control I needed to create the illusion of “persistent” radio stations.
- There is also one specific AirPlay station that enabled AirPlay and stops playing all other music.



Tuning the radio changes music selections.

All software is written in python, source code available on request. The high-level organization consists of 3 modules:

1. A "DialReader" class, which samples the rpi GPIO pins using pigpio in a loop to read the current value of the 12-bit capacitance reading counter. The class also handles doing the math and smoothing to turn the counter value into a frequency and a frequency into an estimate of the current dial position between 50 and 180.
2. A "StaticPlayer" class, which blends pink noise with the station audio according to whether we are in the center of a station's "bandwidth" (no noise, all music), nearing the edge (static blended with music), or fully between stations (all noise, no music).
3. I found a "StationController" class, which keeps track of which stations are loaded at which dial positions, and controls turning stations "on" or "off" depending on the dial position. Stations represent different audio sources, such as a Pandora station, a directory of files on disk, or Airplay.
  - \* For files on disk, stations also keep track of the last time they were played, so that if you listen to a station, leave it for e.g. 10 seconds, and then return to it, the station will seek ahead 10 seconds to preserve the illusion of the song continuing to play while you were on a different station.

- \* For files on disk, stations randomly pick the next song from those available, but filter out up to the last 20 songs played, to prevent excessive repetition.

With a quad-core processor, Raspberry Pi model 3 works particularly well for this application, as one core is typically dedicated to playing audio via ALSA, another to downloading music from Pandora via Pianobar, the third to reading GPIO and orchestrating via the python code, and the fourth to other miscellaneous OS tasks. Initially with this project I used a single-core computer, but the resource contention caused stuttering audio and inconsistent dial reads.

Everything is configured to start up immediately upon boot, and conveniently the Raspberry Pi is able to boot up and launch the program faster than the radio’s vacuum tubes warm up, so there is no noticeable “boot up” time. Plus, as the tubes warm up it creates a nice “fade in” effect on the audio coming out of the Raspberry Pi.

## Reflections

This ended up being quite an ambitious project - because it was a labor of love, I ended up putting a ton of work into the small details like blending static between stations and using the original condenser as the input. The way everything came together made it all worth it, though - the radio is hands-down the coolest project I’ve ever made.

My favorite use for it is listening to it when I’m in my room reading or working on a project - I can just turn it on and enjoy. Plus, the warm sound and physical nature of the interface makes it such a *fun* product to use. After my experience with the radio and other projects, I’m convinced that physical interfaces offer a much more pleasant experience than digital interfaces - they just take quite a bit more effort to make work.

After working on the project off and on for the better part of the year, I gave the original model shown above to my dad for his birthday. I miss it, so I’m now working on retrofitting a second radio for my own use.

## Using the Radio

Operating the radio is very simple to use. If you have used a radio before, it should feel very familiar. The dial on the left turns on the radio and controls the volume, the dial on the right selects the station. There are 14 stations available, shown in the table on the right.

Each station plays songs related to a theme - and just as with normal radio, you simply turn to a station and enjoy what’s playing. If you don’t like the current song, you can always change to a different station, but there’s no way to skip songs or choose a specific song to play. The only exception to this is the “Airplay” station. Tuning to station 160 allows you to connect to the radio via your phone or computer, and wirelessly play any music you desire through the radio.

While the radio has a modern “brain”, it is still very much an antique - treat it with care. The purity of the sound can’t compete with modern amplifiers, but the warm hum and occasional crackle gives the audio a unique quality of its own.

Over time, the vacuum tubes or capacitors may need to be replaced—after all, they’ve been in the radio since before WWII! If your radio needs to be serviced, or you have any other questions about the device, contact the creator at [brettcvz@gmail.com](mailto:brettcvz@gmail.com).

Dial	Station
55	Glasvegas*
60	Sara Bareilles*
65	String Ensemble*
70	Barenaked Ladies*
80	Heartbeats (Jose Gonzalez)*
90	Ed Sheeran*
100	Fleetwood Mac*
110	Classic Radio Addresses
120	Magnets (Halsey)*
130	Wild Things (Alessia Cara)*
140	Classic Sports
150	Train*
160	Airplay
170	Lindsey Stirling*
* Plays related songs via Pandora	

Playlist and dial positions.

---

Mr. van Zuiden is a Product Manager at Clever, a software company dedicated to improving public education.





## Bay Area Radio Hall Of Fame

By David Jackson

The board of directors of the Bay Area Radio Museum and Hall of Fame announced its Class of 2018 on Radio Day, July 31st, the thirteenth group to be honored. The announcement was made at the annual Radio Day By The Bay celebration at the California Historical Radio Society's headquarters in Alameda. BARHOF's Class of 2018 will be celebrated on Saturday, October 13, with a special luncheon at the Basque Cultural Center in South San Francisco, in cooperation with the Broadcast Legends. The members of BARHOF's Class of 2018 include:



Scott Beach

**Scott Beach – Program Host** - Known on the air for his work at KCBS, KSFO and KKHI, the Oregon-born Scott Beach was also an actor (appearing notably in American Graffiti, The Right Stuff, Stand By Me and Mrs. Doubtfire), fabled man-about-town, raconteur and a founder of the long-running improv troupe, The Committee. He passed away in 1996 at the age of 65.

**M. Dung (Michael Slavko) – Program Host** - One of the legendary characters of the airwaves, Dung Boy hosted KFOG's morning show and its "Sunday Night Idiot Show" for the better part of a decade, giving us a dictionary-full of new verbiage, including "Eye!" and "Day!" that didn't mean quite what Webster's definition told us they meant. Mike also worked his Dung magic at K-FOX (KUFY) in the late 1990s. He passed away in June 2017 at the age of 59.

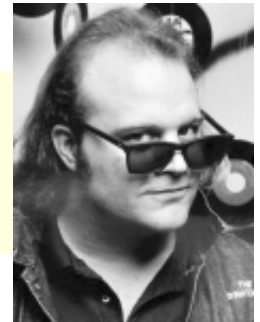

M. Dung



Jon Bristow

**Jon Bristow – Newscaster** - Currently with KCBS, Jon was a reporter and news anchor at KGO for more than 25 years, and joins an ever-growing list of San Francisco State alumni (not to mention KGO alums) in BARHOF.

**Gene Burns – Talk Show Host** - Gene arrived at KGO in 1995 after a long career that took him from his native New York to stops in Philadelphia, Boston and Florida. His 16-year run at KGO included a weeknight program on "the issues of the day" and the Saturday "Dining Around With Gene Burns." Let go by KGO in 2011, he signed on with KGSF early in January 2012 but suffered a debilitating stroke that eventually led to his death in May 2013 at the age of 72.



Gene Burns



Greg Papa

**Greg Papa – Sportscaster** - The radio voice of the Raiders for the past two decades, Greg Papa has attained iconic status as one of the top sportscasters in the United States. A product of Syracuse University – the cradle of sportscasters – Greg currently hosts the early afternoon shift (with Bonta Hill) on 95.7 The Game (KGMZ). He has also broadcast A's and Giants baseball, Warriors basketball, Cal football and basketball, and served as an in-studio host for both the Giants and Warriors broadcasts on NBC Sports Bay Area.



Jude Heller

**Jude Heller – Specialty** - One of the superstars of strategic brand marketing, the roster of Bay Area radio stations that Jude has left her own imprint on includes KFRC, KFOG, KNBR, The Bone, KOIT, K-FOX, The Game and KDFC, to name a few. Yet another San Francisco State product, her promotions work beyond radio included Bill Graham Presents, Lucasfilm and Live Nation and San Francisco’s “Carnival” celebration.

**Fred Krock – Engineering** - In addition to being gifted with one of the grandest voices ever, Fred is among the most distinguished broadcast engineers in the industry. From his earliest days at Stanford, where he served in multiple roles at campus station KZSU, to his work as an announcer and chief engineer at KXXK (which later became KKHI) beginning in the 1950s, through his years at KQED-FM, Fred has also been one of the most valuable and venerable chroniclers of Bay Area radio history since the mid-century. A little-known fact: for many years, Fred has also been the magnificent voice heard on countless railroad videos, treasured by railfans around the world.

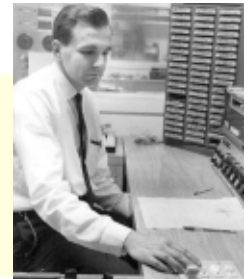

Fred Krock



Gordon Zlot

**Gordon Zlot – Management** - One of the very last of a disappearing breed, Gordon Zlot joins the Bay Area Radio Hall of Fame in recognition of his nearly fifty years of ownership of Redwood Empire Stereocasters in Sonoma County, a quartet of stations that includes KZST, KJZY, KTRY and KWVF. As independently-owned stations disappear from the radio dial in ever-increasing numbers, Gordon and his team continue to produce that rarest and most valuable of broadcast commodities: live, local programming tailored directly to the community it serves.

**Floyd Farr – Pioneer** - A Utah schoolteacher, Floyd Farr found that working in radio during the Great Depression could earn him a better living than a teacher’s salary, which led him to San Francisco, where he rose to chief announcer for KPO and the NBC Red Network on the west coast. In 1947, Floyd became a co-founder of KEEN (1370 AM) in San Jose, also serving as its first general manager and helping to grow their Golden Pacific group to include stations in Lodi, Fresno and Hawaii. Floyd Farr passed away in 1984.

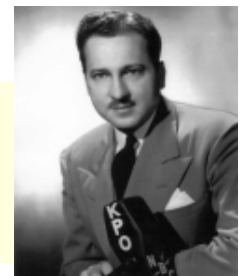

Floyd Farr



Chris Edwards

**Chris Edwards – Legend** - The People’s Choice to be honored with induction into the Bay Area Radio Hall of Fame’s Class of 2018 is Chris Edwards, who arrived fifty years ago in San Francisco for a job that he considered his “golden opportunity” – which it truly was for the self-proclaimed “Big Fat Chrissie” and his legion of fans (each one of them his “Kemosabe”) on 1260/KYA. With his ebullient personality, Chris moved effortlessly into sales and became one of the top account representatives in the business, repping KYA, K101, KSFO, KFRC, KKSF, KABL, KTRB and KGO before his retirement in 2011. Meanwhile, he was always only a heartbeat away from his first love, the microphone, whether hosting the Saturday night “Chris Edwards Time Machine” on K101 and KSFO/KYA-FM or working the amateur airwaves around the world as W6OSV. Chris passed away in January 2014.

**Brian Sussman – Don Sherwood Award** - Brian began working at KSFO as a guest host in 2002 and moved into a full-time role at the station as its evening talk host in 2003. Following the departure of Lee Rodgers, Brian ascended to the lead role on KSFO’s morning program in 2010, where he continues to host one of the most popular conservative talk shows in the nation. He receives this honor as the most popular personality in Bay Area radio following public balloting that attracted nearly 18,000 votes among 30 nominees from local stations in music, news, talk and specialty formats.



Brian Sussman



**KDIA (Lucky 13), Oakland** — One of the truly **Legendary Stations** in the history of American radio, KDIA was a pioneer in specifically serving one of the largest African American audiences in the nation. Beginning its life on the airwaves from Oakland in 1920 as experimental amateur station 6XAM, it became KLS in 1922, and KWBR in 1945 — all under the ownership of founders (and brothers) Stafford and Eugene Warner. The Warner brothers sold the station to Sonderling Broadcasting in 1959, at which time it became KDIA and embarked on its greatest period of growth, popularity and influence.



## KSAN Jive 95: The Movie

Our CHRS Radio Dog Production, “**KSAN Jive 95: The Movie**” continues in production. But making a feature length documentary is costly. We are seeking to raise \$150,000 to produce this film. The KSAN Jive 95 story is perfect for CHRS to tell and immortalize in film as it is an important part of our mission to preserve and present local radio history. KSAN, during the period 1968-1980, was pivotal in the development of our popular culture. This film will raise awareness and refresh remembrances of a time when a radio station could create change and really make a difference in so many ways.

Part of our recent grant from the Rex Foundation was earmarked toward the KSAN Movie project. We commissioned famous poster artist Wes Wilson for a movie poster. Wes and his daughter Shirryl Bayless collaborated to create this outstanding poster.

Now it's your turn to help. Please visit [www.ksanjive95themovie.com](http://www.ksanjive95themovie.com) and see how you can get great perks for donating to this project and help to preserve the KSAN Jive 95 legacy.

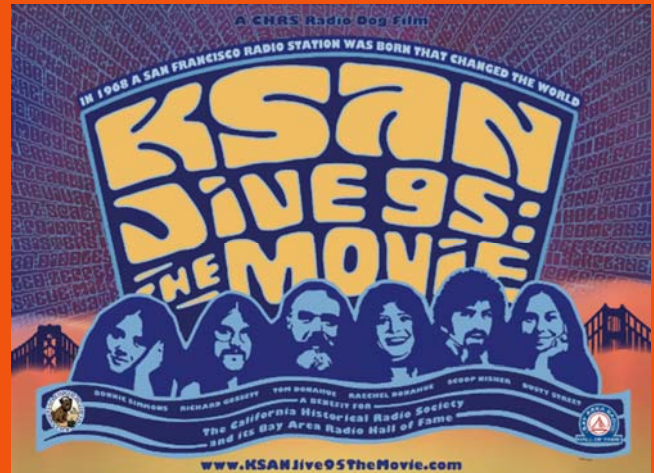

## CHRS Publications

**The Radio Boys And Girls—Radio, Telegraph, Telephone and Wireless Adventures for Juvenile Readers 1890-1945** is the latest book by Mike Adams. It captures the genre of series fiction about wireless and radio was a popular in young adult literature at the turn of the 20th century and a form of early social media. Before television and the Internet, books about plucky youths braving danger and adventure with the help of wireless communication brought young people together. They gathered in basements to build crystal. They built transmitters and talked to each other across neighborhoods, cities and states. By 1920, there was music on the airwaves and boys and girls tuned in on homemade radios, inspired by their favorite stories.

This book covers more than 50 volumes of wireless and radio themed fiction, offering a unique perspective on the world presented to young readers of the day. The values, attitudes, culture and technology of a century ago are discussed, many of them still debated today, including immigration, gun violence, race, bullying and economic inequality.

Available now at Amazon.com

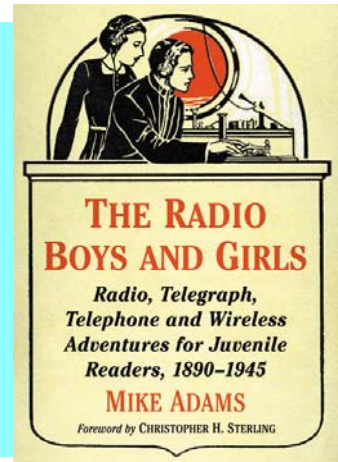

**The Story of KPEN: A Concept in Great Radio!** CHRS member and Broadcast Legend Gary Gielow has written a new book chronicling the tales of two young men from Stanford, he and James Gabbert, who brought Stereo and new ideas to the FM radio band in the late 1950s and 1960s. This book is the definitive history of KPEN 101.3 FM, the 2015 BARHOF Legendary Station. 100% of the proceeds benefit CHRS.

Available in the Museum Store or on the website.

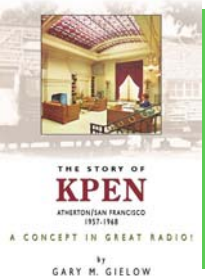

Also available in the museum store

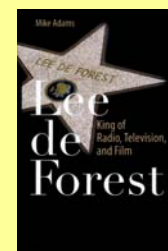

Lee de Forest



Bay Area Radio



**Behind the Front Panel: The Design and Development of 1920's Radio** by David Rutland has been re-mastered by Richard Watts for CHRS. With emphasis on radio technology, Rutland describes the development of 1920s tubes and radio circuitry designs by De Forest, Marconi, and other inventors and manufacturers. A classic! Buy at Amazon.com

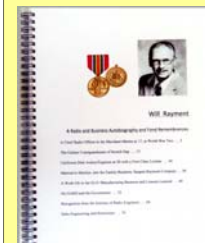

Will Rayment



KSAN Live Jive CD



# More Radio Day

