

The Making of a Radio Repairman, 1950 - 1960

By: Stanley Pitman

10 September 2015

This article is a summary of knowledge and experience gained in over ten years in the repair of radios (and later of TVs), augmented by subsequent insights derived from my years in electronic engineering. I'll explain first about how I came to be in the business, followed by a short history of my employment. Then I'll cover some of the radio technology of that and prior eras, along with some related repair issues, and close with some anecdotes you might find interesting. Although this focuses on radio, my companion article for TVs is posted on EarlyTelevision.org (search for "repairman").

Part 1 : The Early Years

My earliest memories of involvement with the wonders of technology were at the age of three, during pre-TV days in World War 2. We had a table-top radio that sat on a sideboard, and I was very curious about how those little tiny people inside the radio could talk and play music so loud. When I almost pulled the radio off onto the floor seeking to see them in there, I was very disappointed to see mostly only round glass tubes, and I was barked at severely by my wicked stepfather.

When I was nine, we left the relative comfort of our rented house in town, and moved to a shack in "the boonies", with no electricity or indoor plumbing. For a while we had radio entertainment via a "farm radio" powered by monster battery packs (including A, B and C batteries), but they were very expensive and were later cut from the budget (I think mostly to afford more beer). But we did have a wind-up phonograph and a collection of 78 RPM records, most of which were 1-sided and about 20 years old. Records could be played with steel needles, which caused wear and tear on the grooves in the shellac record, or with softer cactus needles, which had to be swapped out after a few plays.

In the 6th grade I was introduced to SCIENCE, including the real magic of magnetism and electricity. We wound wire around nails to make electromagnets, and built telegraph keys and sounders. Then a neighbor kid and I strung wires between our houses and exchanged secret Morse code messages. All this was done with 1.5-volt carbon-zinc cells — big round honkers the size of a salt box.

My first direct experience with AC power came in 6th grade when, egged on by several of my cronies, I wired up a 6-volt DC doorbell with a 110-volt plug and plugged it into a classroom wall socket during recess. The resultant 3-second flash and clamoring bell cleared the room in about 11 seconds. When we cautiously sneaked back in and retrieved our experiment, we found that the bell contacts had vaporized and the magnetic coils were charred. So went my first lesson in higher voltages and power.

About this time, I heard rumors about old-time radios that didn't need batteries or other power and someone explained to me about "crystal set" receivers. These were simple circuits with a rectifier to turn radio frequencies into audio signals to feed a pair of earphones. The simplest radio shown in figure 1 would only work well in a town with only one radio station.

From a mail-order site, I bought a crystal detector assembly and instructions for making a radio. A friend of my uncle gave me a slider-adjustable coil that he had wound on a round Quaker Oats box when he was a kid. After cadging a few more parts here and there, I put it together on a piece of wood and had my first radio, shown in figure 2. We strung a long antenna wire in the yard, and pounded a 6-foot ground rod into the earth outside my window.

My first detector was a chunk of galena potted in a small cup of lead. This was mounted with a sharp-pointed pivoting wire (sometimes called a cat's whisker) to contact the detector surface. To get reception, you had to listen on the earphones while probing around the detector surface to find a spot that gave the best signal. If you bumped the board or yanked on the earphone cord, you lost contact and had to start over. Later on, my uncle told me about a fixed germanium diode (1N34), which solved that problem. Performance left a

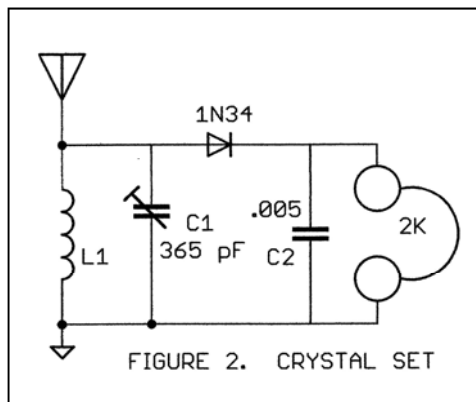
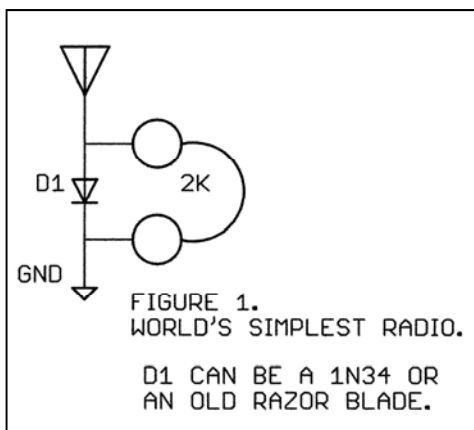

lot to be desired, as the selectivity was very bad. The “Q” of the tuning circuit was very low, dragged down by the low impedance of the detector, and local 50-kilowatt station KGO swamped lower-powered stations in the area. I made a 30-foot earphone extension cord, so my mother could have music in the kitchen while pressing clothes with irons heated on our wood stove.

Note: Galena is mostly lead sulfide, and is the prime ore for obtaining lead and silver. The point-contact junction forms a small primitive Schottky diode, with a low forward voltage of about 0.4 volts. This was similar to the technique used later in the first transistors. The only point-contact diodes in wide use today are silicon units used in microwave receivers. 1N34 diodes are still available today, in a package 1/20th the size of the originals.

To read more about these types of old-time radios, access Wikipedia.com and look for CRYSTAL SETS.

My tech education during this period was hampered by not having access to people who were knowledgeable about radio, as well as by my having no AC power. And much of what I learned came from a 25-year-old book called “The Home Radio; How to make and use it”. So you can imagine just how up-to-date my knowledge was. But the book did teach me how to make my own capacitors, called condensers in those days, using wax paper and foil from cigarette packs. I also made resistors, drawn with pencil graphite on cardboard. The resistors were even adjustable, requiring only careful use of an eraser. This came in handy for optimizing the grid-leak bias on my first one-tube radio, with a grid leak detector, shown in figure 3. It was fun to build, but after a month of batteries eating up my meager allowance, I went back to my crystal set.

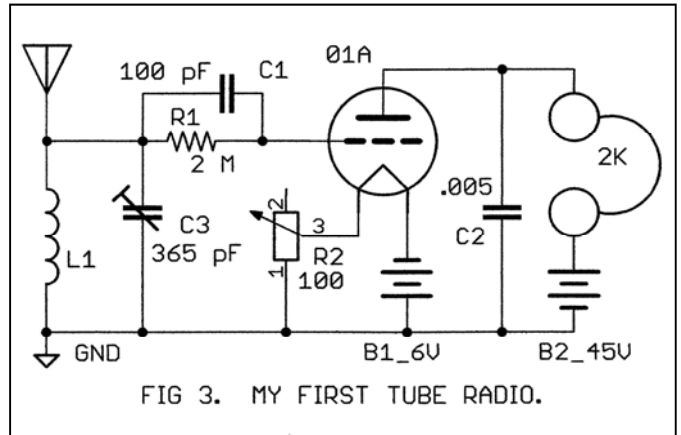

FIG 3. MY FIRST TUBE RADIO.

In the 8th grade I got a job in a radio and TV repair shop. Mostly I kept the place clean, tested radio and TV tubes, and answered the phone when the boss was out. In return, he taught me a lot about radios and how to solder and replace components, while paying me a minuscule wage

Part 2 : High School Years

I worked at paper routes to support my tinkering habit, getting and fixing up radios to resell, and kept one of the better ones, which had a tuned RF (TRF) stage at the antenna end for greater sensitivity and selectivity. I became a “DX junkie”, often combing the broadcast band for distant US stations until the wee small hours, and then had problems dozing off in class.

I built several simple portable radios, which I carried around school to listen to during breaks. What made these radios feasible was a new type of radio-frequency (RF) inductor with a ferrite core and very high “Q.” The single tube was a 1U4 pentode in a regenerative circuit with controlled positive feedback for high sensitivity, as shown in figure 4. Because power needs were modest, I was able to use batteries that didn’t have enough juice left for regular radios, and several repair shops saved their customers’ old batteries for me.

My first experience with ferrite coils was when I got the harebrained idea that the AC wiring in our house would make a good antenna for my simple radios. Apparently, lessons from my earlier experience with the doorbell had faded from my mind or gotten filed in the wrong drawer. So I connected the coil between a ground pipe outside and one leg of an AC plug, with no blocking capacitor. OOPS --- must’ve chosen the wrong leg (wall sockets weren’t polarized in those days). I can snicker about it now, but memories of the hours I spent refinishing my mom’s burnt dining room table after the resultant fire are permanently etched in my brain.

I started listening to short wave stations on an old Zenith console radio, but was unable to read the on-

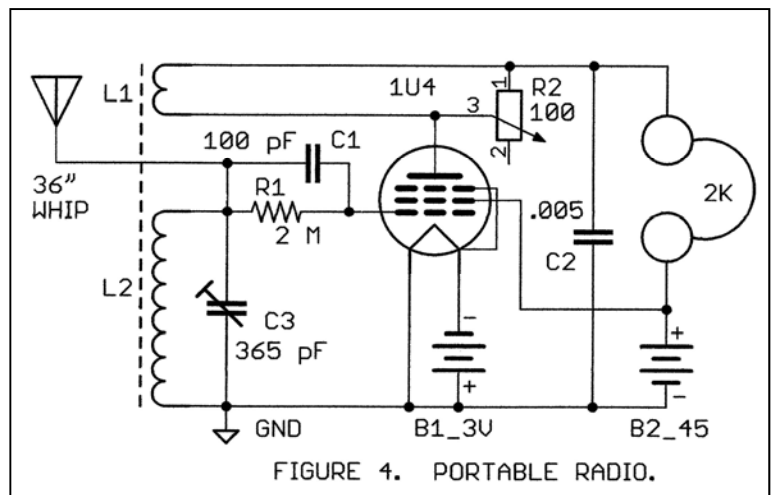

FIGURE 4. PORTABLE RADIO.

off clicks of CW Morse code messages. So I built a one-tube beat frequency oscillator (BFO) to get an audible BEEP BEEP. I got to be fairly proficient at the code, while studying radio theory and operation so I could pass exams for my Novice radio amateur license, and I became KN6GGL.

I bought a used Hallicrafters S38-C receiver with ham band coverage, and built my own CW transmitter from info in a ham manual. It was mounted on a plank, breadboard style, with a single type 1614 tube (a 12 volt version of a metal 6L6, from the electronics surplus store). Because the voltage from my makeshift power supply was high, the tube ran too hot, so I inverted the whole shebang over a bucket of cool water. I was the probably the only novice ham in Los Angeles with a water-cooled transmitter. I'm pretty sure I was running over my legal limit of 75 watts, but had no test gear to check power or anything else. My unit was at least crystal-controlled, so I think the frequency was probably OK.

I held my novice license for the allotted year, but never practiced the code enough to get up to the next-level General class requirement of 13 words per minute. I made about 75 domestic radio contacts (or QSOs), mostly on the West Coast, plus two in Canada and a rare one in Australia. Not bad for a cheapo receiver and a home-brewed oscillator feeding a simple dipole antenna.

Part 3 : The World of Work

My first job after graduating in 1955 was at a TV repair shop in Hollywood, working at fixing radios and as general flunky and TV repair trainee. My old-school boss was not a good communicator, but I was a voracious learner, and my barrage of questions about troubleshooting techniques probably annoyed him at times. In addition to the work in the shop, I sometimes got to go with the outside repairman on service calls, and even met a few film and TV celebrities when we went to their sumptuous homes for repairs.

During this time I was taking night courses in electronics at L.A. City College. In these classes and in electronic magazines, I was exposed to relatively newfangled things called transistors. I was eager to learn more, but my Neanderthal boss assured me that they would never amount to much of anything, saying they were too slow, noisy, expensive and hard to troubleshoot. Despite my disappointment at that, I bought some anyway and built a few simple circuits. He was right about one thing, though; they were expensive. The Raytheon PNP silicon CK722 units cost \$1 apiece (about an hour in my 1955 wages, or over \$40 at today's pay rate).

Two years of apprenticeship taught me enough to get journeyman repair positions at several shops over the next few years. The changing technology offered a lot to learn, as semiconductors became more common. In 1959, I bailed out of consumer electronics to do test and repair of aerospace instrumentation.

After a seven-year stint investigating security matters as a US Army Intelligence Agent, I spent six years as chief technician and production manager with a manufacturer of electronic security gear. I then joined a scientific apparatus firm, and have mostly worked on engineering of radiation-related instruments and systems for the last 35 years. My early education and adventures in Radioland served me well over the ensuing years, in occasionally dealing with RF from 100 kilohertz to 10 gigahertz.

Part 4 : Radio Technology

Most info in this section comes from my experience working on various kinds of tube radios, from home-brewed units built in the 1920s to the end of the tube era, augmented by later research into their historical development. Early sets were usually simple detectors such as crystal sets, as described above. These were soon followed by vacuum tube circuits, which were used for a myriad of purposes. We'll start with the basics.

Earliest radio tubes had no sockets, relying on flying leads wired into circuits. Early 4-pin triodes with plug-in bases were not standardized, with variations in pin diameter and length. Some sockets had a bayonet-pin push-and twist base.

DETECTORS:

Most vacuum tubes are designed to be operated with their control grids more negative than their cathodes, biasing them into their linear operating range for accurate amplification. Early tube detectors used a grid-leak circuit, with grid near cathode potential and a resistor/capacitor combo in the grid return path. This caused non-linear one-sided clipping of the RF signal, in effect making it a sloppy half-wave rectifier, with output smoothed by capacitors in grid and plate circuits to recover an amplified version of the original modulating audio signal. Because the grid attracts electrons during positive RF half-cycles, it develops negative bias via its R/C combo to stabilize the whole process. Most grid-leak detectors were configured as "regenerative" circuits, with a controllable positive feedback loop between plate and grid via a "tickler" coil. For AM reception, properly adjusting loop gain just short of that to cause oscillation gave far greater gain and selectivity, allowing simpler and less expensive radios. Disadvantages of regenerative detectors included frequent readjustment of feedback level

when changing stations, and interference with other receivers if feedback loop gain was set high enough to cause oscillation. Sometimes oscillation was intentionally induced to provide a BFO action to enable audible CW Morse code reception, called "Autodyne" mode.

Early tubes had directly heated cathode/filaments. But in the late 1920s tubes with indirectly heated (i.e. isolated) cathodes became available, allowing much simpler self-biasing of detectors and amplifiers by inserting resistors in cathode leads to raise them above ground. The type 27 tube was likely the first to make "plate detectors" feasible, which were soon adopted to phase out troublesome regenerative detectors, while increased gain in newer RF tube types reduced the need for highly sensitive detector stages.

Isolated cathodes also simplified design of diode detectors, using tubes like the dual 6H6, with the added benefit of AVC (automatic volume control). Later audio tubes like types 75, 6SQ7 and 6AV6 integrated the diodes into the first audio tube.

RF ARCHITECTURE:

Multi-stage radios are often classified by their RF circuitry design. TRF (tuned radio frequency) sets, both home-brewed and factory built, had one or more RF gain stages ahead of the detector, with each having a separate tuning capacitor and dial. Cascaded RF amplifiers give increased gain and selectivity, but were tedious to tune for optimal reception. Stray "Miller" capacitance in triode tubes and wiring could cause oscillation and instability. Problems were reduced by patented "Neutrodyne" circuitry like in figure 5, where CN is used to cancel positive feedback CM. Later development of screen-grid tetrode tubes reduced tube capacitance and usually made neutralization unnecessary. Many later TRF sets ganged two to four tuning capacitors together with one dial, simplifying tuning, but tracking was less than ideal. A small amount of regeneration was often used in the RF amplifiers for increased gain.

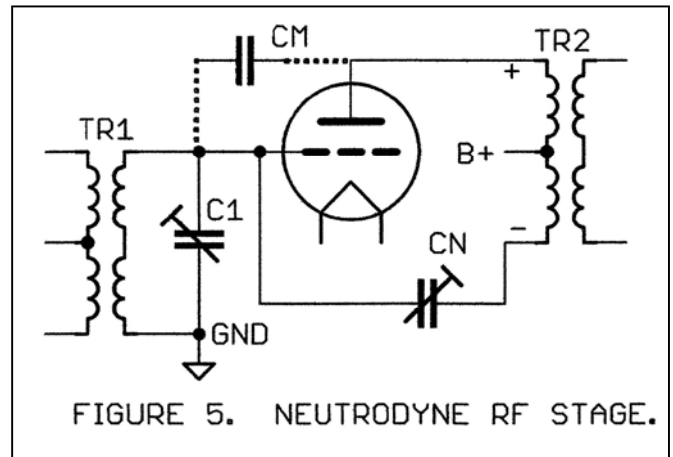

Superheterodyne receivers were invented in 1918 by Edwin Armstrong, but were slow to be adopted, in spite of their superior sensitivity and selectivity. They mix incoming and local oscillator signals to yield a fixed intermediate frequency (IF), which can be more conveniently processed than the original signals, as tubes of that time had much more gain at low frequencies. Early superhet models were harder for casual users to operate, and more expensive because of increased parts cost and high patent expenses. Armstrong's patent had been sold to RCA, which monopolized the superhet receiver market until about 1930. But by the mid-1930s, nearly all receivers sold were superhets. The superhet "mixer" stage generating the IF frequency was sometimes called a 1st detector, and the one demodulating the audio was a 2nd detector. Armstrong had to use troublesome triode mixers, but in 1933 pentagrid converters combined mixer and oscillator in one tube, improving sensitivity and reliability at lower cost.

Although some early radios used variable inductors, most tuning was by variable capacitors (condensers) via large front-panel dials/knobs. Since tuning frequency changes logarithmically with capacitance, later sets usually had capacitors with specially-contoured geometry to space the stations more evenly on their dials. Since superhet RF and oscillator frequencies differ, their tuning capacitors were usually of different sizes, or adjustable "padder" condensers were used to make their frequencies track correctly. Capacitors in radios used in dusty areas would accumulate debris between the plates, causing noisy tuning, and we used a 400-volt DC supply to zap it out. Frequency dials and capacitors in later years were usually driven by "dial cord", which tended to slip after long use. This could often be alleviated by tightening the cord tension spring, or by using special dial cord "goop".

Although large loop antennas were used with some early sets, and smaller ones in post-war years, most pre-war sets used a wire antenna. A short one inside the house was usually enough for local stations, but a longer and higher one outside was needed for more distant reception. Some early radios (including crystal sets) had connections for short or long antennas, and sometimes had a resonant circuit to tune the antenna itself. A good earth ground connection was essential for best reception on early radios, although most later AC-powered sets got by with coupling the circuit ground to one side of the power line via a capacitor. Loop antennas were mostly phased out after "loopstick" ferrite units came out in about 1952.

Automatic volume control (AVC) circuits were patented in about 1925, and were ubiquitous by 1930. These used the rectified DC level of the diode detector to control bias on RF and IF stages to control their gain, and the audio fed a pot to control audio

amplifier level. Earlier sets manually varied RF gain by a pot controlling antenna input or RF/IF cathode biasing or plate voltage, or a combination of these.

Metal tube shields are an important part of an RF design, and missing ones can cause spurious oscillations and other problems.

AUDIO STAGES:

Audio amplifiers in early radios used C batteries for bias. Since they supplied virtually no current, they usually lasted for their shelf life. Later sets were cathode-biased, so no C voltage was needed. Output stages were mostly single-ended, with a hi-Z (high-impedance) speaker or earphones or an output transformer in the plate circuit coupled to a low-Z speaker. Some sets used a choke in the plate circuit, and capacitively coupled audio to earphones or a hi-Z speaker.

In addition to wooden cabinets and better speakers, most multi-tube radios made other attempts to shape audio response for most pleasant sound. The plates of audio stages were usually bypassed with small capacitors to tame shrillness, and most larger sets had some kind of tone switches or controls.

HEADPHONES & SPEAKERS:

Successful headphones were in wide use for crystal and tube receivers by about 1920. They had 1000 to 2000 ohm moving-iron drivers with single-ended or balanced armatures. Soon some of these were coupled to "morning glory" horns from phonographs to make the first horn speakers for radios. In a few years, the horns were replaced by flexible cones attached to similar hi-Z moving-iron drivers.

Note: Horns act like acoustical transformers, matching the acoustic impedance at the driver end to that of the room air. There's even an acoustical ohm.

Although low-Z dynamic (moving coil) speakers were first patented in 1898, they were little used before the mid-1920s except for P.A. systems. In 1924, patented improvements in mechanical parameters resolved resonance problems and improved sound quality, leading to their wider use. Suitable permanent magnets of the time were very expensive, so early dynamic speakers used electromagnets called field coils, energized by B(+) or B(-) current drawn by the radio. This winding usually acted also as a choke coil, filtering AC ripple in the power supply. However, the ripple current caused similar modulation of the magnetic field, causing some audible hum. On many later sets, a "hum-bucking" coil winding in the field coil connected to the voice coil to cancel residual hum. One unusual radio I repaired appeared at first to have no audio output transformer. A closer look revealed that the speaker's field coil was a two-winding transformer, so the audio output tube drove both the voice coil and its magnetic field. Development of Alnico alloy during World War II made speaker magnets much cheaper and smaller, and led to the demise of troublesome field coils.

POWER SUPPLIES:

Early tube radio filaments were designed to work with available "A" batteries. 1-to-1.5-volt devices were intended for 1.5-volt zinc-carbon dry-cells, 2 volt units were made for single lead-acid cells. 5-volt tubes like the type 01-A variants, the best selling tubes in the 1920s, were made to work with 6-volt lead-acid batteries, as were later 6-volt tubes. 5-volt tubes used a variable "rheostat" to control filament current. 45-to-90 volt "B" batteries and lower voltage "C" batteries were usually zinc-carbon stacks.

6-volt lead-acid A batteries were easily rechargeable, but B batteries were expensive, so in the mid-1920s many people used AC-powered B-battery eliminators, which were eclipsed by AC sets in few years.

Early AC powered sets often used tubes with directly heated 2.5-volt filaments, and the power transformer filament winding was grounded at a tap in the middle, or to a rheostat across the winding so that residual hum could be balanced out. Later transformer sets mostly used 6-volt isolated-cathode tubes to further reduce hum. Most sets supplied B(+) via a type 80 rectifier tube, or its later octal 5Y3 equivalent. Some larger sets used a type 83 gas filled tube for lower voltage drop.

Development of transformerless AC/DC radios starting in the mid-1930s was driven mostly by cost. They were cheaper, lighter and smaller, but came with their own set of problems. Filaments of the same current were series-strung, with voltages to meet each stage's power needs, and an extra resistance element was added to give 300 mA at 115-volt line. This element was usually a plug-in ballast tube or added resistance wire in the line cord. 1939 brought tubes with higher filament voltages, to add up to 117 and eliminate the filament resistors. Tube type 35Z5, the most common octal rectifier, had a filament tapped to feed a 6-volt dial-light. This design approach gradually morphed into an "All-American Five" (AA5) tube line-up made with minor variations by over 100 American manufacturers.

Please see part 5 for important info on the special shock hazards of early AC-DC AA5 sets.

A significant variation on AC-DC tube radios was “3-way” sets, which also operated off batteries. Probably the best-known of these was the multi-band Zenith Transoceanic, first made briefly in 1942 and then after the war until 1962. In AC operation, all power was via a 117-volt rectifier tube, which was changed to a selenium rectifier in later models. Since the 9-volt series string of directly-heated tube filaments didn’t allow isolated-cathode biasing, the designers cleverly arranged the filament string so that the tubes needing the highest cathode bias were near the top of the string. Grid return paths were routed further down on the string or to ground, eliminating need for a C battery. Transistorized models were produced from 1957 to 1981.

CAR RADIOS:

The first commercially-made car radios appeared in 1930. Paul Galvin had been making battery eliminators to allow battery-powered radios to run on household AC current. But as more homes were wired for electricity, more radio manufacturers made AC-powered radios, and Galvin needed a new product line. He joined with William Lear and Elmer Wavering in adapting home radio designs to the car environment. But it wasn't as easy as it sounds. Automobiles had generators, sparkplugs, and other electrical equipment that generate noisy static interference. It took two men several days to install a radio, as the dashboard had to be taken apart and the ceiling be cut open to install the antenna. “The Motorola” cost about \$110, about \$3,000 in today’s money, at a time when the country was sliding into the Great Depression and a brand-new car cost \$650. Galvin lost money for a couple of years, but things picked up in 1933 when Ford began offering Motorolas pre-installed at the factory. By 1934, B.F. Goodrich tire stores were selling them for \$55, installation included. Lear and Wavering went on, separately, to invent or develop automotive alternators, eight-track tape players and the Lear Jet, among other wonders.

Car radios were similar to their AC or portable cousins in most ways, with a few adaptations for the hostile automotive environment of vibration, electrical noise and dirt. High voltage was derived via a transformer and rectifier tube, usually a vacuum type 6X5 but sometimes a gas-filled type 0Z4 per figure 6. This type of rectifier had no filament, and less conduction losses, to save on power needs. The transformer was driven by a mechanical vibrator, which switched power to alternate sides of the center-tapped primary at about a 60 Hz rate. Some early models had a synchronous vibrator with a second set of contacts in the transformer secondary circuit to commutate (rectify) the voltage without a rectifier tube.

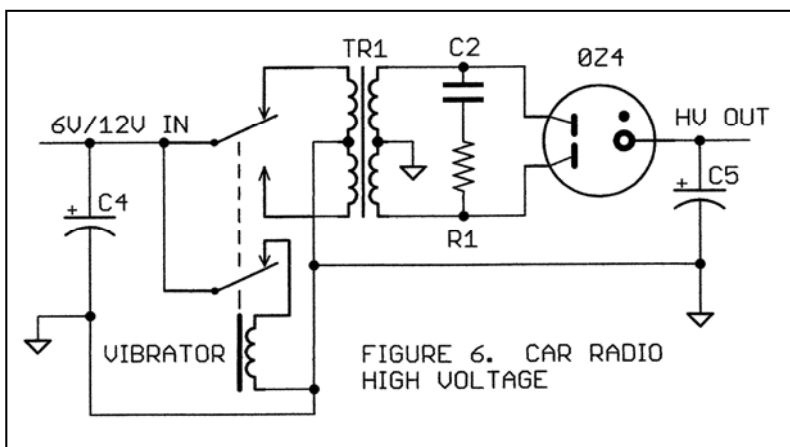

Vibrators were prone to pitting of their contacts after long use, causing them to stick and blow the main power fuse. Transformer secondaries were fitted with a “snubber” circuit to dampen the interfering spikes generated by abrupt switching of inductive circuits. Solid-state plug-in replacement vibrators are available

Although tuning capacitors were used early on, later car radios usually had ganged variable coils, tuned with ferrite cores, and IF frequency of 262 kHz. Automakers used various methods for signal-seeking tuning, with GM cars favoring spring-driven clockwork, rewound by a solenoid after each dial run-through. Ford used a small electric motor for two way scanning.

First use of transistors in car radios was about 1958 in the Corvette, which used them in a multivibrator switching supply for high voltage generation. In the late 50s, tubes were developed that could operate with only 12 volts plate supply, and audio stages were powered by transistors. Improvements in transistor frequency range to the RF range soon eliminated tubes altogether.

Part 5 : Troubleshooting and Repair

Figure 7 illustrates the strong shock hazard posed by AC/DC sets. Most early versions of these sets had all B(-) connections grounded to the chassis, including one side of the switched line cord. If the radio is ON with the unpolarized power cord plugged in the “wrong” way, it’s obvious the “hot” INPUT B will make the chassis potentially lethal. What’s not so obvious is that if the plug is reversed, the “hot” INPUT A will make the chassis “live” with the switch OFF, with current limited only by the cold filament resistance string. So there is really no safe polarity. And missing knobs or screws or rotted rubber mounting grommets can be hazardous. Some otherwise-well-built later radios, such as the Hallicrafters SX-41, had a live chassis.

This was later remedied by using a semi-floating internal B(-) ground bus, which was still connected to the chassis via a paralleled 0.1 microfarad capacitor and a 220K resistor. The capacitor serves to couple IF can and tube shields to circuit

ground, as well as an RF ground conduit for antenna input. If the cap is shorted or leaks, you're back to a live chassis again.

It's safest to work on AC-DC sets using an isolation transformer, especially if you'll be connecting any AC-powered test gear. You can make your own, using back-to-back filament or power transformers of appropriate power. Another shock hazard on older sets was exposed B(+) voltages for connection to earphones or speakers connected into the plate circuit of audio output stages.

Beyond tube failures, the most frequent problems were caused by capacitors, especially aluminum electrolytic units used for power supplies and bypassing. These polarized devices sometimes shorted, but most often developed high internal resistance due to loss of conducting electrolyte. In power supply filtering, this causes excessive 120-Hz ripple and hum. Those used in other sections for bypassing can cause many symptoms, including lower audio output or "motorboating" low-frequency oscillation. Early "wet" capacitors (with water-based electrolyte) were singly chassis mounted, but later "dry" (gel-based) parts were usually in shared packages. The thin aluminum oxide dielectric (energy-storing) layer in these capacitors is formed on the specially-treated anode metal, and the electrolyte contacts the outer can (on early parts) or the cathode foil (on later "dry" parts).

When radios have been unpowered for a very long time, electrolytic capacitors tend to lose their dielectric layer and their voltage rating. They may destroy themselves and other parts when re-powered, unless slow-start techniques are used to renew their dielectric. When restarting long-idle sets, it's best to use a variable-voltage (Variac) transformer to increase voltage slowly over several days. Note that Variacs are usually not isolated. An alternative method is to power up with an incandescent lamp socket in series with the AC line, starting with a 60-watt bulb and decreasing the wattage gradually.

Shorting or leakage in other capacitor types can allow current to flow where it shouldn't. Bad coupling capacitors can cause a following stage to draw excessive current. When repairing any set, it's a good idea to check for proper circuit voltages in their vicinity. Older tubular capacitors usually had a dielectric of wax-impregnated paper, and any parts showing wax leakage should also be replaced.

Regular carbon composition resistors seldom went bad, unless burned by other failures, but power resistors were a bit more prone to opening up. Open grid resistors can cause distortion and other hard-to-diagnose symptoms.

Measuring grid voltages in tube circuits should only be done with a high-impedance meter. Vacuum-tube voltmeters (VTVMs) had an isolating 1-Megohm resistor in the DC probe at the tip, whereas DVMs usually do not. Non-isolated probes can give unreliable results due to oscillation and other problems.

Be wary of replacing rectifier tubes with "improved" solid-state substitutes, as they will raise B(+) voltage and likely damage capacitors.

Part 6 : Odds and Ends

The 1930s saw its share of "tube-count wars", as evidenced by inflated claims of improved performance by some sets with more tubes. Some AC-DC sets claimed the filament ballast resistor as a tube. Some brands used two or three IF or audio stages at reduced gain, or a pentode as a diode detector. History repeated itself in the late 1950s, when some radios with higher than average transistor count had some of them soldered into the board but not connected.

I restored several 1920s Crosley radios that were tuned with "book" capacitors. These were a pile of foil and insulation, loosely sandwiched together, which were squeezed together by a knob-driven cam. These were likely the ancestors of the later compression trimmer capacitors used for alignment.

Right after World War II, some radio tube types were very scarce, and manufacturers got quite creative. I worked on several sets that were a mixture of octal, locktal and 6 or 7 pin tubes. The ultimate example was a set using six 6V6 audio power tubes for all functions, including detector and rectifier. Early Heathkit amplifiers used military surplus tubes with 12-volt filaments, because they were available and very cheap.

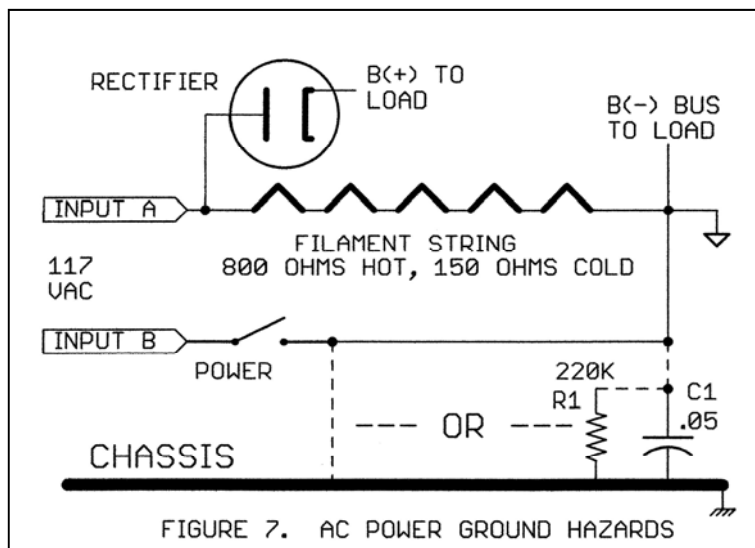

The most interesting radio I ever repaired was a highly unusual hybrid. There were only two 01-A tubes, but the set had two tuned RF circuits and an audio transformer, along with a crystal detector on the front panel. Circuit tracing revealed it to be a “reflex” circuit, shown in figure 8, with the RF signal amplified by both stages, then passed to the galena chunk for detection. The audio then fed back through the same stages to drive a pair of earphones. Because RF and audio frequencies are so far apart, an arrangement of chokes and coupling capacitors allowed the set to perform like a four-tube radio, using half the current. So you got a four-tube radio while paying for two tubes, and batteries lasted twice as long. Basically, they had a crystal set with added boost fore and aft.

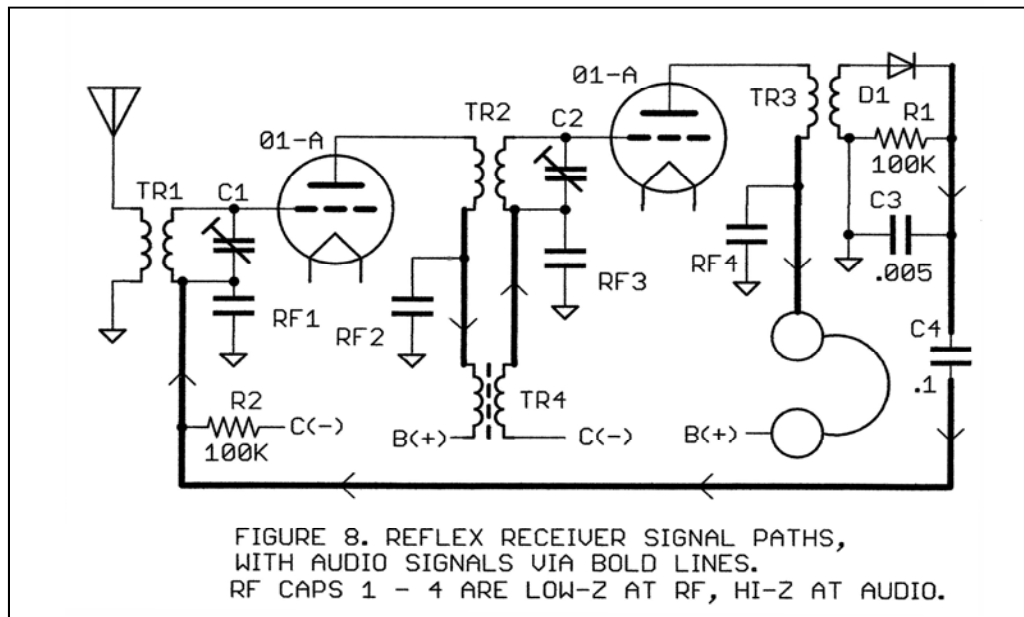

Part 7 : Service Stories

Once I brought a woman’s console radio into the shop to replace defective filter capacitors. After I fixed that, the set sounded a little shrill, and I discovered and replaced an open tone-shaping capacitor. When I returned her set and told her how I’d improved the tone, she listened intently for a moment. Then she asked “What have you done with my treble? I want you to march right back down to the shop and put my treble back in.” She remained adamant, so I opened up the set and snipped out the shaping capacitor, restoring her smile in the process.

As in most repair businesses, we dealt with our share of Do-It-Yourselfers. They would often use the tube tester at the corner drugstore, buy a bunch of tubes that measured “weak”, then bring the set in when that didn’t fix the problem. When servicing sets, we didn’t usually replace tubes that were marginally weak, unless symptoms dictated otherwise. We also used to get radios where the DIY guy had helpfully tightened down the loose screws on those little square cans (IF transformer trimmers).

Many customers had very convenient memories when it came to service calls. I often heard the refrain of “You were just out here recently, and it’s doing the same thing again.”

Fortunately we kept pretty good records, and were able to ferret out that it was often at least six months ago and for an entirely different problem, or sometimes even for a different set !

Part 8 : Acknowledgments

While researching and writing this article about long-ago technology, I found myself returning time and again to several reliable sources for detailed info and clarification. My thanks, for their articles and archives, to CHRS at www.californiahistoricalradio.com and SCARS Southern California Antique Radio Society (SCARS) at www.AntiqueRadios.org. And my very special thanks to Wikipedia (en.wikipedia.org) for the immense mass of detailed info on most of the subjects and terminology covered in this paper.

This article was formatted and edited for Mr. Pitman by CHRS and posted on the CHRS website.

© Copyright 2015 by Stanley Pitman

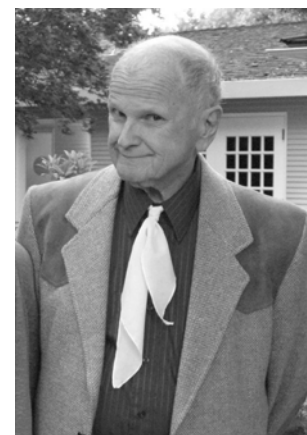

The author, Stanley Pitman